

Decorative Lighting



features: luminaire in contemporary design for post-top mounting | optical enclosure of clear transparent or stippled glass | light control possible by available range of reflector inserts | decorative housing elements for system completion | housing metallic grey powder coated | luminaires available in any customised colour | for elliptical high pressure sodium and mercury lamps

application: particularly suitable for lighting of squares, pedestrian precincts, open car parks, residential areas, side roads and parks | to be used for post top in single or multiple installations or for wall mounting | recommended mounting height from 3 to 5 meters

design: the luminaire is based on a modular system | strong post mounting element made of die cast aluminium for 76mm spigot | optical enclosure made of UV-stabilised acrylic PMMA material | top cover canopy made of aluminium | replaceable electrical module includes the gear, lamp holder and optical reflector accessories | extremely weather-resistant finishing



Order No.	Description	Lamps	Weight
5NX 524 2-1CF18	post top lantern with stippled PMMA diffuser, aluminium canopy, complete with gear, p.f. corrected, metallic grey	1 x 80/125 W HME elliptical lamp	11.0 kg
5NX 524 2-1MF18	post top lantern with stippled PMMA diffuser, aluminium canopy, complete with gear, p.f. corrected, metallic grey	1 x 50/70W HSE elliptical lamp	11.5 kg
5NX 524 2-1NF18	post top lantern with stippled PMMA diffuser, aluminium canopy, complete with gear, p.f. corrected, metallic grey	1 x 100W HSE elliptical lamp	12.2 kg
5NX 524 2-1CS18	post top lantern with clear PMMA diffuser, aluminium canopy, complete with gear, p.f. corrected, metallic grey	1 x 80/125 W HME elliptical lamp	11.0 kg
5NX 524 2-1MS18	post top lantern with clear PMMA diffuser, aluminium canopy, complete with gear, p.f. corrected, metallic grey	1 x 50/70W HSE elliptical lamp	11.5 kg
5NX 524 2-1NS18	post top lantern with clear PMMA diffuser, aluminium canopy, complete with gear, p.f. corrected, metallic grey	1 x 100W HSE elliptical lamp	12.2 kg



1. lantern with decorative frame DE LUXE
2. lantern with decorative frame CLASSIC

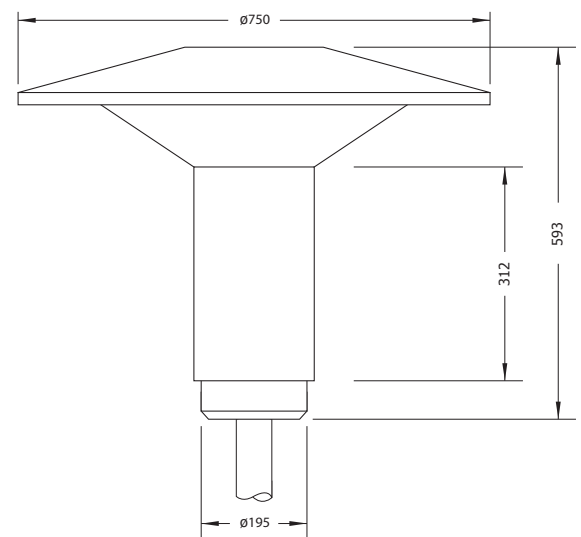

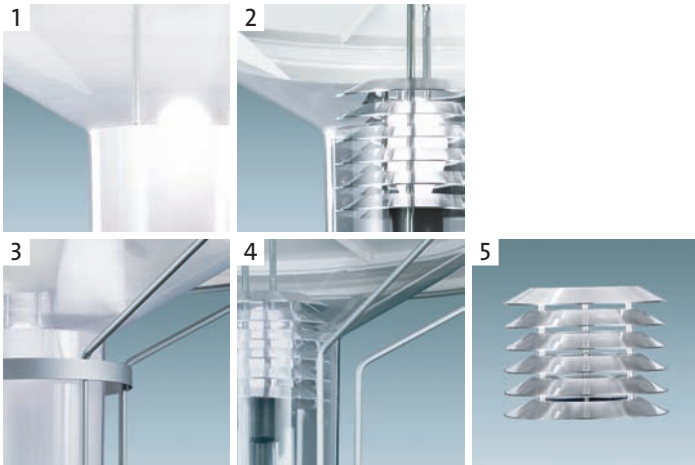

1. stippled PMMA diffuser
2. clear PMMA diffuser
3. decorative frame CLASSIC
4. decorative frame DE LUXE
5. circular fan-shaped reflector

spare parts & accessories:

Order No.	Description	Size	Weight
5NX 527 0-038	decorative frame "DE LUXE", aluminium, powder coated, grey metallic, complete with mounting ring and screws	270 / 740 x 460 mm	1.8 kg
5NX 527 0-048	decorative frame "CLASSIC", aluminium, powder coated, grey metallic, complete with mounting ring and screws	270 / 740 x 460 mm	1.9 kg
5NC 547 0-0XG	optical enclosure / diffuser, clear transparent PMMA	200 / 590 x 415 mm	1.4 kg
5NA 547 0-1XG	optical enclosure / diffuser, stippled PMMA	200 / 590 x 415 mm	1.4 kg
5NX 520 0-0XS	circular fan-shaped reflector for glare limitation, anodised plastic, complete	185 x 170 mm	0.4 kg
5NX 520 0-3XS	anti glare ring, aluminium	185 x 170 mm	0.3 kg

technical data:

- rated voltage: 230 or 240V, 50Hz
(other voltage available on request)
- circuit arrangement: p.f. corrected
- ambient temperature: -20°C....+40°C
- protection class: IP 54
- windage area: 0.16m²

installation:

easy mounting of the post-top with attached electrical module (76 mm spigot) by three M8 screws, self-centering | electrical connection by a screw terminal for wire cross section up to 4.0 mm² | insert of the diffuser | screwing of the canopy by one centre screw

service and maintenance:

easy access for lamp replacement and periodic maintenance through the screwed-on top canopy | no tooling required

light distribution curve:

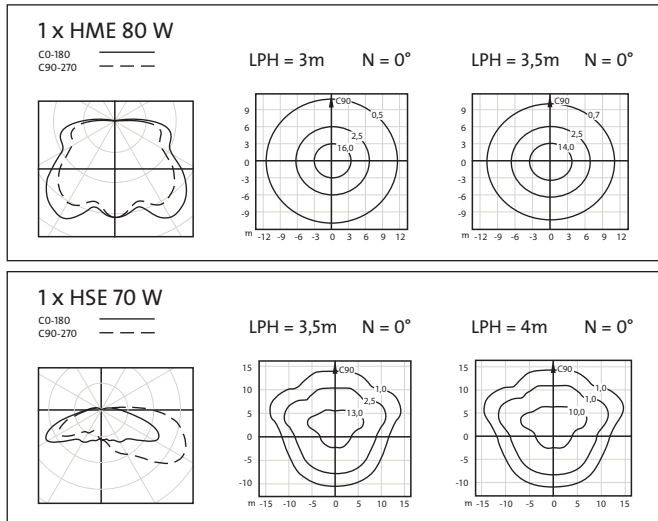

logistic:

the luminaire modules are packed in three carton boxes | the cartons may be loaded individually or stacked on pallets | for delivery of larger quantity few canopies and diffusers may be packed together

	carton
800 x 800 x 100 mm (l x w x h) 220 x 220 x 600 mm (l x w x h) 600 x 600 x 430 mm (l x w x h)	

	weight
16.0 kg (3 cartons)	

	pallet
2-8 units	

	container
20' : 11 pallets, 88 units 40' : 22 pallets, 176 units	