

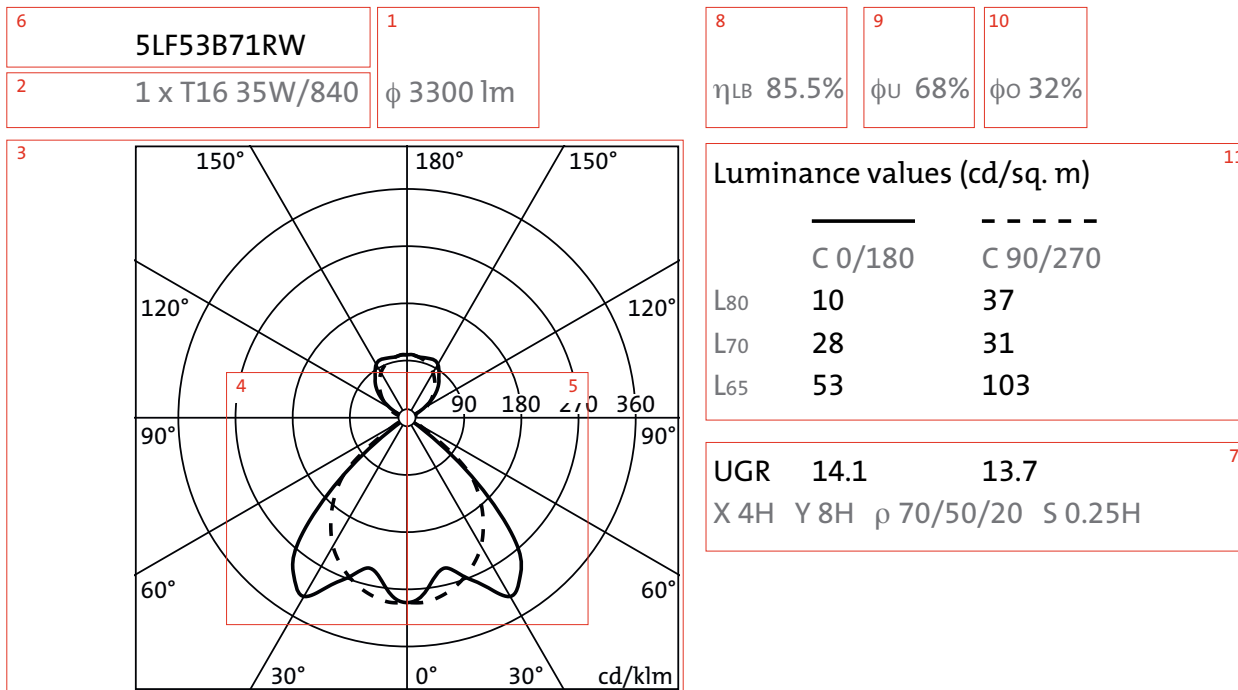

Appendix

Photometric Data Information	page 2
Emission Angle Information	page 7
Icons and Diagrams	page 8
Lamp Data	page 14
Power Consumption	page 18
Power Factor Correction	page 19
Luminaires with Integral Emergency Inverter	page 20
Light Quality	page 22
Standards, Directives and Lighting Information	page 24
Siteco Services	page 25
Order Number Index	page 26
Sales and Delivery Conditions	page 35
Siteco Contacts	page 36

Light distribution curve



- | | | |
|---|--|--|
| <p>1 ϕ: Luminous flux of lamps in [lm] according to lamp manufacturer specifications, measured at 25°C ambient temperature and in unshielded state. With LED: luminous flux of luminaire.</p> | <p>7 UGR value: specification for direct glare control (unified glare rating) with indoor luminaires. Extract from the standard table for room width X = 4 x H, room length Y = 8 x H, with reflection factors $\rho_{\text{ceiling}} = 70\%$, $\rho_{\text{wall}} = 50\%$ and $\rho_{\text{floor}} = 20\%$
H: distance between eye level of seated viewer (1.2 m) and luminaire level.
Value left: with luminaire/lamp axis parallel to X, across direction of view.
Value right: with luminaire/lamp axis parallel to Y and along direction of view.
S = 0.25 m: axis distance of luminaires among each other. This is not realistic but is used for the specification of the table.
With luminaires having indirect components greater than 15 %, these are determined with a 50 cm suspension distance (drop height) from ceiling.
The UGR process cannot be used for luminaires with indirect components greater than 65%.</p> | <p>10 ϕ_O: component of luminous flux emitted to the upper hemisphere (indirect component, $\gamma > 90^\circ$), in [%] from total luminous flux $\phi \times \eta_{LB}$ leaving the luminaire.</p> |
| <p>2 Number, type and colour temperature of lamps, usually according to ZVEI lamp designation system.</p> | <p>8 Light output ratio η_{LB} in [%]:
This specifies how much luminous flux ϕ of the lamps (in %) actually leaves the luminaire at an ambient temperature of 25°C.</p> | <p>11 Luminance levels at luminaire in [cd/sq. metre] on levels C0° and C180° or C90° and C270° with various γ angles:
L80: luminance with $\gamma = 80^\circ$,
L70: luminance with $\gamma = 70^\circ$,
L65: luminance with $\gamma = 65^\circ$
DSE-compliant (display screen equipment) glare control, when L < 1000cd/sq. metre is valid in all C levels for $\gamma \geq 65^\circ$.</p> |
| <p>3 Light output as polar curve.
Specification of γ-angle in [°]
Specification of light output I in [cd/klm].
Actual light output valuations are calculated by multiplication with light output of the lamp in [lm], divided by 1000.
Centre of circular matrix (scale of light output I) or initial point of circular matrix (scale of γ-angle) is the focal light point of the luminaire or the centre of the light emission surface</p> | <p>9 ϕ_U: component of luminous flux emitted to the lower hemisphere (direct component, $\gamma \leq 90^\circ$), in [%] from total luminous flux $\phi \times \eta_{LB}$ leaving the luminaire.</p> | <p>Photometric data specifications are based upon measurement results with goniophotometers and Ulbricht spheres according to valid measurement criteria and are only significant for the specified luminaire type in combination with specified light sources. Depending upon the type of luminaire, the most reasonable or possible specifications are selected.</p> <p>More detailed photometric information concerning all products can be found at www.siteco.com</p> |
| <p>4 Continuous line:
Light output I at C180°
Dotted line:
Light output I at C270°</p> | | |
| <p>5 Continuous line:
Light output I at C0°
Dotted line:
Light output I at C90°</p> | | |
| <p>6 Order number of luminaire, with accessories where applicable</p> | | |

Supplementary photometric explanations for downlights and suspended hall luminaires.

5NG15603QM1

1 x HIT-DE 150W/730 ϕ 11700 lm

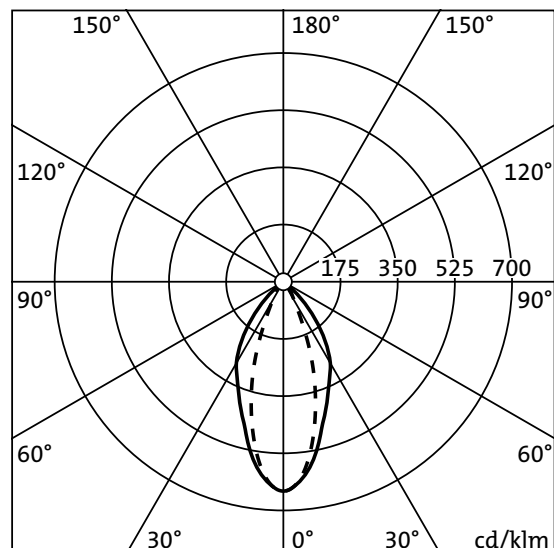

η_{LB} 41%

I_{max} 641 cd/klm at γ 0° 12

Luminance values (cd/sq. m)

	—————	- - - - -
	C 0/180	C 90/270
L80	1778	1778
L70	1805	1354
L65	4383	2557

α 50%	2 x 26.2°	2 x 17.4°	13
α 10%	2 x 47.3°	2 x 30.4°	

UGR 28.4 21.6
X 4H Y 8H ρ 70/50/20 S 0.25H

12 I_{max} : Maximal light output I in [cd/klm] and γ -angle at which this occurs.

13 α 50%: half-peak divergence in [°]. This specifies at which angle light output I is still equivalent to 50% of the maximal value I_{max} .

α 10%: one-tenth peak divergence in [°]. This specifies at which angle light output I is still equivalent to 10 % of the maximal value I_{max} . Angle specifications usually define the sum of angles in the levels C0° and C180° or C90° and C270°, e.g. 2 x 10°

14 Light output as diagrams based on Cartesian coordinates with levels C0° and C180° as well as C90° and C270°

Additional photometric explanations for narrow distribution spotlights/projectors for outdoor applications

5AA32270K

1 x HIT-TC-CE 20W/830 ϕ 1615 lm

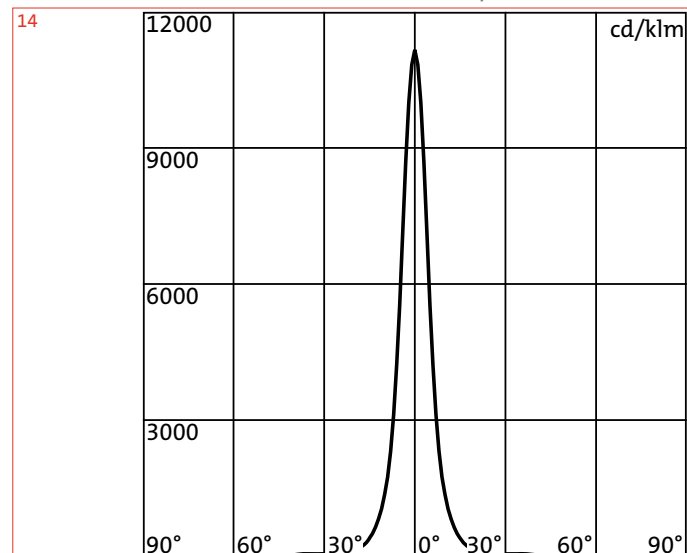

I_{max} 11162 cd/klm at γ 0°

	—————	- - - - -	14
	C 0/180	C 90/270	
α 50%	2 x 5.0°	2 x 5.0°	
α 10%	2 x 10.8°	2 x 10.8°	

Supplementary photometric explanations for asymmetric floodlights

5NA75901WS03

1 x HIT-DE 2000W Longarc ϕ 230000 l_m

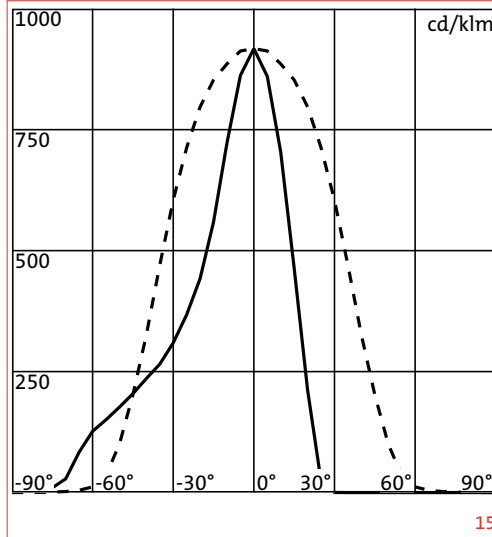
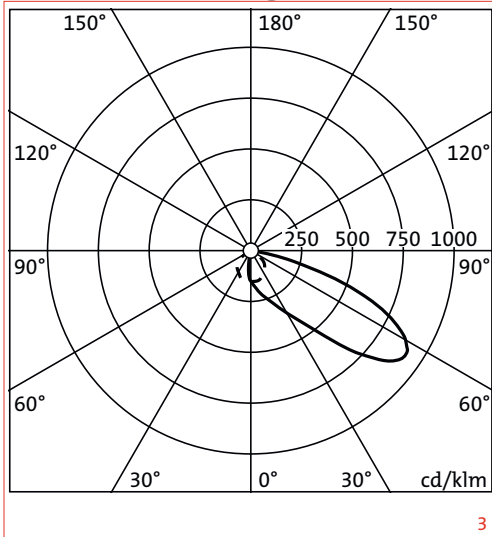

η_{LB} 80,4%

I_{max} 917 cd/klm

Tilt angle 56°

— A 0 (C 0/180) - - - B 0 15

15 Light output as a diagram based on Cartesian coordinates with levels A0° (identical with levels C0° and C180°) and level B0°.

16 Tilt: with floodlights the luminaire is tilted before measuring so far that the maximum in levels A0 and B0 is equivalent to $\gamma = 0^\circ$. In this way, the width of light emission can be more precisely determined during measurement than with a measurement with C levels, thus

achieving a higher measurement accuracy. Some luminaires were measured with C levels; here no tilt is specified. The tilt angle in the Cartesian diagram corresponds to the angle to which the floodlight in the polar curve emits light asymmetrically to the vertical.

Light Cone Diagram

In the case of rotosymmetrical distribution luminaires, the light cone diagram describes the illuminance values occurring on the measuring plane with respect to the distance to the luminaire vertically to the light direction. The cone shell and thus the circular intersections between cone and planes are described by the half-peak divergence, i.e. the angle at which light output is still 50 % of maximum light output. Within these circles the medial illuminance E_m and the maximal illuminance E_{max} are specified with a maintenance factor of 0.8.

17	H(m)	18	ϕ (m)	19	E_{max} (lx)	20	E_m (lx)
	1		1,78		422		267
	2		3,55		106		67
	3		5,33		47		30
	4		7,10		26		17
	5		8,88		17		11

Maintenance factor = 0.8

17 Distance of plane to luminaire in [m]

18 Diameter of light cone in [m]

19 Maximal horizontal illuminance E_{max} within light cone in [lx]

20 Medial horizontal illuminance E_m within light cone in [lx]

Isolux Curve/Individual Luminaire

Isolux diagrams represent illuminance distribution upon virtual or real surfaces, e.g. on a road, floor or wall. Points of equal illuminance E in [lx] ('Isolux') are connected with a curve. The illuminance values are dependent upon the distance between luminaire and surface. A maintenance factor of 0.8 is applied. Isolux diagrams demonstrate the effect of the lighting characteristics of a luminaire (rotosymmetrical/asymmetric/linear).

Mounting height 10 m Tilt 0°

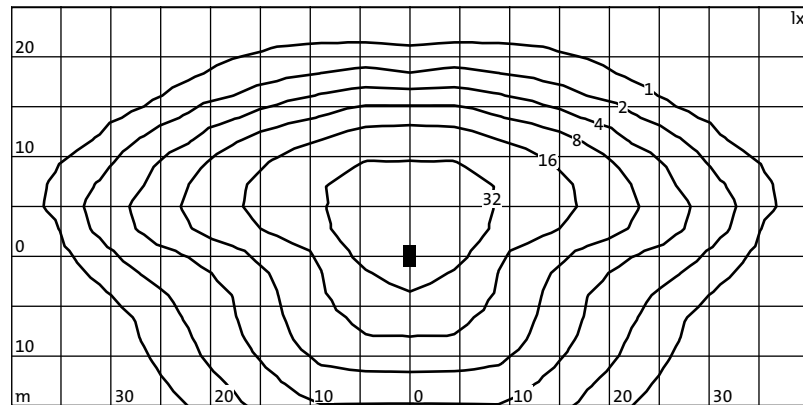

Number of Luminaires Within Room

Tabular representation of the required number of luminaires per square metre for a specified nominal horizontal illuminance value E_m in [lx], on a 0,75 m working plane for two standard room heights L_h [m]. These values are based upon standard reflection factors $\rho_{\text{ceiling}} = 70\%$, $\rho_{\text{wall}} = 50\%$, $\rho_{\text{floor}} = 20\%$ and a maintenance factor of 0.8. For calculating the tabular values according to other lamp variations, the specified number of luminaires in the table must be multiplied by the corresponding factor.

No. luminaires in room
Reflection factor 70/50/20

E_m (lx)	100		200		500	
L_h (m)	2,5	3,0	2,5	3,0	2,5	3,0
20 qm	1,2	1,4	2,4	2,7	6,0	6,8
30 qm	1,9	2,1	3,8	4,2	9,4	11
40 qm	2,4	2,7	4,8	5,3	12	13
50 qm	2,9	3,2	5,9	6,4	15	16
75 qm	4,3	4,6	8,7	9,3	22	23
100 qm	5,6	6,0	11	12	28	30
500 qm	27	27	53	54	133	136

Factors for other lamp configurations
2 x 36W 0,5
Maintenance factor 0,8

Isolux Curve/Workstation Illumination

The Isolux diagram represents the distribution of the horizontal illuminance E in [lx] upon a virtual plane at a height of 0.75 m above the floor (the working plane). An all-round distance of 0.5 m to the wall surface is maintained. Points of equal illuminance ('Isolux') are connected with a curve. A standard room is used with length of 5 m, width of 3.5 m and clearance height of 2.7 m. The room surfaces have reflection values of $\rho_{\text{ceiling}} = 80\%$, $\rho_{\text{wall}} = 50\%$ and $\rho_{\text{floor}} = 30\%$. The room contains a double workstation with table length of 1.6 m and table width of 2 x 0.8 m. The room is illuminated with a floorstanding luminaire and a maintenance factor of 0.8 was used. Below the diagram the medial horizontal illuminance E_m in [lx] is specified within the room or on the table surface at a height of 0.75 m.

Office with double workstation
Room 5 x 3,5 x 2,7 m Working plane h 0,75 m

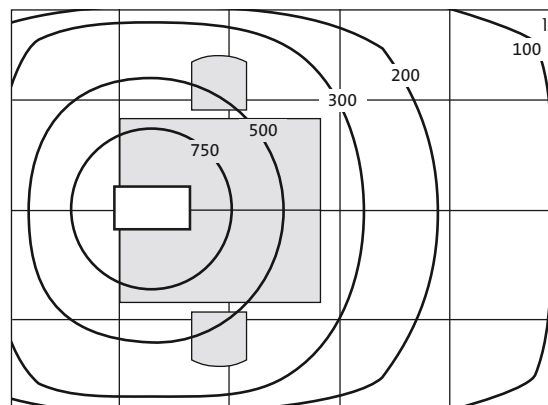

Reflection factor 80/50/30 Maintenance factor 0,8
 E_m room 447 lx E_m table 643 lx

Isolux Curve/Room Illumination

The Isolux diagram represents the distribution of the horizontal illuminance E in [lx] upon a virtual plane at a height of 0.75 m above the floor (the working plane). An all-round distance of 0.5 m to the wall surface is maintained.

Points of equal illuminance ('Isolux') are connected with a curve. A standard office room is used with length of 5 m, width of 3.5 m and clearance height of 2.7 m. The room surfaces have reflection values of $\rho_{\text{ceiling}} = 70\%$, $\rho_{\text{wall}} = 50\%$, $\rho_{\text{floor}} = 20\%$.

The room contains a double workstation with table length of 1.6 m and table width of 2 x 0.8 m. The room is illuminated with two direct/indirect distribution suspended luminaires. A maintenance factor of 0.8 was used. Below the diagram the medial horizontal illuminance E_m in [lx] is specified within the room or on the work surface at a height of 0.75 m. According to DIN EN 12464-1 the following uniform values $g_1 = E_{\text{min}} / E_m$ must be maintained: table: $g_1 \geq 0.7$; room: $g_1 \geq 0.5$

Office with double workstation
Room 5 x 3,5 x 2,7 m Working plane h 0,75 m

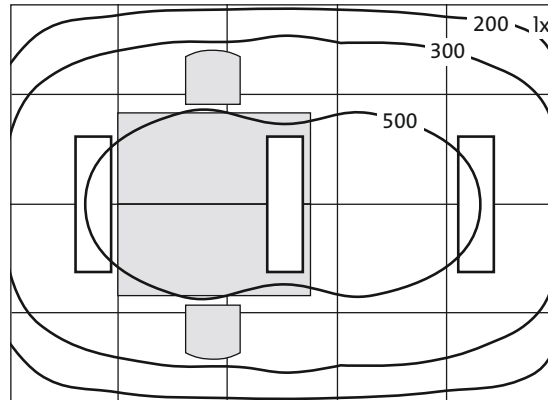

Reflection factor 70/50/20 Maintenance factor 0,8
 E_m room 481 lx E_m table 535 lx

Isolux/Table Wallwasher

5LR73501HA51 1 x HIT-CE 70W
Distance to wall (DW) 1 m

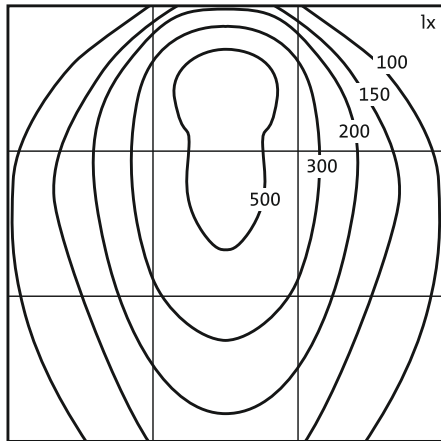

Planning parameters	Presentation of luminaires in room
Reflection factor 70/50/20 Maintenance factor 0,8 Room height 3 m Tilt 20°	

DW (m)	1,00	1,00	1,25	1,25	1,50	1,50	DW distance luminaire/wall in m
DL (m)	1,00	1,25	1,25	1,50	1,50	1,75	DL distance luminaire/vertical luminaire in m
E_m (lx)	353	349	306	304	263	260	E_m [lx] medial illuminance value

The Isolux diagram represents the distribution of the vertical illuminance E_v in [lx] upon a virtual wall surface with a height of 3 m or 6 m (vertical working plane). Points of equal illuminance ('Isolux') are connected with a curve. A wall surface is used with a width of 3.0 m.

The room surfaces have reflection values of $\rho_{\text{ceiling}} = 70\%$, $\rho_{\text{wall}} = 50\%$, $\rho_{\text{floor}} = 20\%$.

The wall is targeted with a luminaire with asymmetrical distribution, positioned with a specified distance to the wall (DW) and centric to the wall.

The table shows the medial illuminance values E_m in [lx] of two luminaires with the specified distance to the wall (DW) and the distance of luminaire to luminaire (DL).

A maintenance factor of 0.8 was used. Below the dia-

gram the medial vertical illuminance value E_m in [lx] at the wall is specified. Measurement is tilted so far that the maximum in levels A0 and B0 is equivalent to $\gamma = 0^\circ$. In this way, the width of the light emission can be more precisely determined during measurement than with a measurement with C levels, thus enabling a higher measurement accuracy. Some luminaires were measured with C levels; here no tilt is specified.

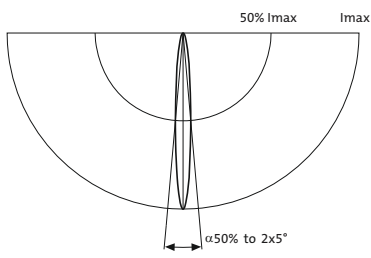

extremely narrow distribution

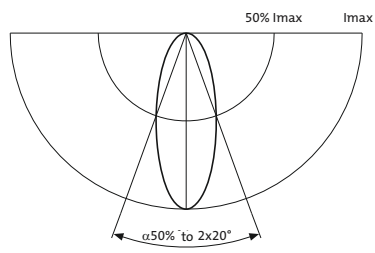

narrow distribution

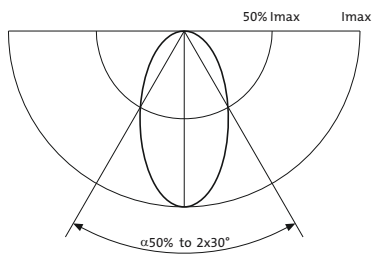

medium distribution

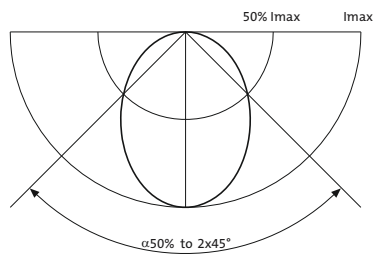

wide distribution

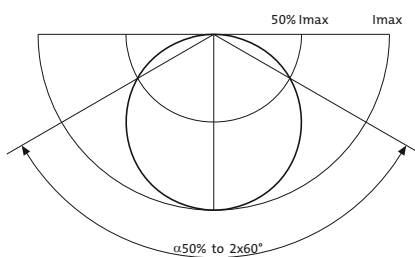

extremely wide distribution

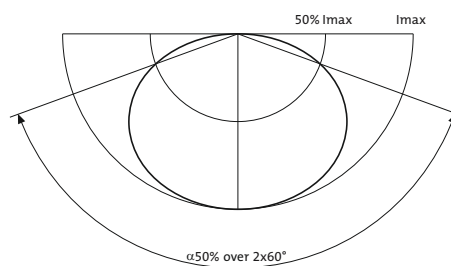

diffuse distribution

Light Distribution

	Recessed ceiling luminaire, direct wide/diffuse distribution		Ceiling surface-mounted luminaire direct diffuse distribution		Suspended luminaire direct wide/diffuse distribution
	Recessed ceiling luminaire, direct medium/wide distribution		Ceiling surface-mounted luminaire direct wide/diffuse distribution		Suspended luminaire direct medium/wide distribution
	Recessed ceiling luminaire, direct narrow distribution		Ceiling surface-mounted luminaire direct medium/wide distribution		Suspended luminaire direct/indirect medium/wide distribution
	Recessed ceiling floor/wallwasher		Ceiling surface-mounted luminaire direct medium/wide distribution with ceiling illumination		Suspended luminaire direct narrow distribution
	Ceiling recessed wallwasher		Ceiling surface-mounted luminaire direct narrow distribution		Suspended luminaire direct asymmetrical distribution
	Ceiling semi-recessed luminaire direct wide/diffuse distribution with ceiling illumination		Ceiling surface-mounted luminaire direct asymmetrical narrow distribution		Suspended floor/wallwasher
	Ceiling semi-recessed luminaire direct wide/diffuse distribution		Asymmetrical floodlight Ceiling surface mounted		Suspended wallwasher
	Ceiling semi-recessed luminaire direct medium/wide distribution		Floor/wallwasher ceiling surface mounted		Suspended ceilingwasher
	Ceiling semi-recessed luminaire direct narrow distribution		Wallwasher ceiling surface mounted		Spotlight on suspended system rail, direct narrow distribution
	Ceiling recessed directional spotlight tiltable narrow distribution		Symmetrical floodlight ceiling surface mounted narrow distribution		Suspended luminaire indirect medium/wide distribution
	Ceiling recessed directional spotlight tiltable medium distribution		Projector ceiling surface mounted narrow distribution		Floorstanding luminaire direct/indirect medium/wide distribution
	Ceiling recessed wallwasher tiltable		Suspended luminaire direct/indirect wide/diffuse distribution		Asymmetrical floodlight mast mounted

Light Distribution



Symmetrical floodlight
mast mounted, narrow distribution
Projector
mast mounted, narrow distribution



Wall surface-mounted luminaire
indirect asymmetrical narrow
distribution



Wall surface-mounted luminaire
direct/indirect
narrow distribution



Wall surface-mounted luminaire
diffuse distribution



Wall surface-mounted luminaire
direct asymmetrical narrow
distribution



Ceilingwasher
wall recessed



Wall surface-mounted luminaire
direct/indirect
medium/wide distribution



Wall surface-mounted luminaire
direct narrow distribution



Asymmetrical floodlight
ground installation



Wall surface-mounted
ceilingwasher



Wall surface-mounted luminaire
direct medium/wide distribution



Symmetrical floodlight
ground installation
narrow distribution
Projector
ground installation
narrow distribution



Wall surface-mounted luminaire
indirect medium/wide distribution



Asymmetrical floodlight
wall surface mounted



Wall surface-mounted luminaire
indirect narrow distribution



Symmetrical floodlight
wall surface mounted
narrow distribution
Projector
wall surface mounted
narrow distribution

Lamps



T16
G5
Tubular fluorescent lamp, d=16mm,
for ECG, double ended



TC-D
G24d-1
Twin double tube compact fluorescent
lamp for LLCG, plug-in base



TC-TELI
2G8-1
Triple double tube compact
fluorescent lamp for high ambient
temperatures, for ECG, Bayonet base



T26
G13
Tubular fluorescent lamp, d=26mm,
for LLCG or ECG, double ended



TC-DEL
G24q-1
Twin double tube compact
fluorescent lamp for ECG,
plug-in base



TC-L
2G11
Double tube compact fluorescent
lamp for LLCG and ECG, plug-in base



TC-S
G23
Double tube compact fluorescent
lamp for LLCG, plug-in base



TC-T
GX24d-1
Triple double tube compact
fluorescent lamp for LLCG,
plug-in base



TCR-TSE
flat
GX53
Triple double tube compact
fluorescent lamp,
integrated ECG



TC-SEL
2G7
Double tube compact fluorescent
lamp for ECG, plug-in base



TC-TEL
GX24q-1
Triple double tube compact
fluorescent lamp for ECG,
plug-in base



T16-R
2GX13
Circular fluorescent lamp for ECG,
plug-in base

Lamps

 TC-DD GR8	Fluorescent lamp with looped bulb for LLCG, plug-in base	 HIT E40	Metal halide lamp with tubular bulb and quartz discharge tube, screw base	 HST-CRI GX12-1	High pressure sodium lamp with tubular bulb and ceramic arc tube, plug-in base
 HIE E27	Metal halide lamp with ellipsoid bulb and quartz discharge tube, screw base	 HIT-DE-CE RX7s	Metal halide lamp with tubular bulb and ceramic arc tube, double ended	 QT12 GY6,35	Low voltage halogen incandescent lamp with tubular bulb, plug-in base
 HIE-CE E27	Metal halide lamp with ellipsoid bulb and ceramic arc tube, screw base	 HIT-DE RX7s	Metal halide lamp with tubular bulb and quartz discharge tube, double ended	 QR-CBC 51/IRC GU5,3	Low voltage halogen incandescent lamp with reflector, plug-in base
 HIT-TC-CE PGJ5	Metal halide lamp with tubular bulb and ceramic arc tube, bayonet base	 HIT-DE	Metal halide lamp with tubular bulb and quartz discharge tube, double ended	 QT32 E27	High voltage halogen incandescent lamp with tubular bulb, screw base
 HIT-TC-CE GU6,5	Metal halide lamp with tubular bulb and ceramic arc tube, bayonet base	 HIT-DE	Metal halide lamp with tubular bulb and quartz discharge tube, double ended	 QT-DE11/12 R7s	High voltage halogen incandescent lamp with tubular bulb, double ended
 HIT-TC-CE G8,5	Metal halide lamp with tubular bulb and ceramic arc tube, plug-in base	 HME E27	Mercury lamp with ellipsoid bulb, screw base	 QPAR51 GU10	High voltage halogen incandescent lamp with reflector, bayonet base
 HIT-CE G12	Metal halide lamp with tubular bulb and ceramic arc tube, plug-in base	 HSE-1 E27	High pressure sodium lamp with ellipsoid bulb, internal ignitor, screw base	 A E27	High voltage incandescent lamp with ellipsoid bulb, screw base
 HIT-CE E27	Metal halide lamp with tubular bulb and ceramic arc tube, screw base	 HSE E27	High pressure sodium lamp with ellipsoid bulb, screw base	 IT E14	High voltage incandescent lamp with tubular bulb, screw base
 HIT-CE-od PGZ12	Metal halide lamp with tubular bulb and ceramic arc tube, bayonet base	 HST E27	High pressure sodium lamp with tubular bulb, screw base	 LED	LED
 HIT G12	Metal halide lamp with tubular bulb and quartz discharge tube, plug-in base	 HST-DE RX7s	High pressure sodium lamp with tubular bulb, double ended		

Certification Symbols



The ENEC symbol (European Norm Electrical Certification) is a European test and certification symbol for luminaires and electrical components in luminaires.

It indicates conformity with the relevant European standards on safety and functionality. The suffix 10 indicates that the test has been carried out by the VDE. The VDE symbol may also be affixed to the luminaire.



Luminaires with VDE symbol are tested by the VDE testing and certification institute. The tests are based on the relevant Germany safety standards. The VDE symbol includes the "Safety Tested" symbol.



Protection against touching active, live parts with a finger.



Protection against touching active parts with a finger and against ingress of water jets (e.g. rain). In accordance with EN 60598 indoor luminaires are tested subject to the relevant installation situation with regard to the protection level against ingress of water jets. The Protection level IP x3 is therefore dependent on the installation and not a characteristic of the luminaire. For this reason, all IP20 designated indoor luminaires also fulfil the requirements for the protection level IP23.



Protection against touching active, live parts with a 1 mm thick wire.



Protection against touching active, live parts with a 1 mm thick wire and against ingress of water spray.



Protection against touching active, live parts with a 1 mm thick wire and against ingress of splashwater.



Dust-proof luminaire.



Dust-proof and splashwater-proof luminaire.



Dust-proof and water jet-proof luminaire.



Dust-tight luminaire



Dust-tight and water jet-proof luminaire.



Dust-tight and water jet-proof luminaire.



Dust-tight and water-tight luminaire



Protection against electric shock is based on insulation and connection of all exposed metal parts with the protective earth conductor.



Live parts are equipped with additional protective insulation. Connection of a protective earth conductor is not permitted.



Protection against electric shock is based on use of safety extra low voltage.



Luminaires bearing the F symbol are suitable for mounting on normally flammable building materials (EN 60 598 /VDE 0711).



Luminaires bearing the FF symbol are suitable for plants with a fire hazard due to dust or fibrous materials (VDE 0710, Part 5). In accordance with EN 60 598-2-24, this symbol was replaced by the D symbol on 1.8.05.



Luminaires with D symbols are suitable for plants with a fire hazard due to dust or fibrous materials (EN 60 598-2-24). This symbol replaced the FF symbol (VDE 0710, Part 5) on 1.8.05.



Luminaires are approved for use in explosion hazard zone 2 in accordance with Explosion Hazard Directive 94/9/EC1). Explosion hazard zone 2 in accordance with regulation (EU) 2014/54 (Explosion Protection Regulation): Areas in which an explosive atmosphere due to gases, vapours or mist is unlikely to occur, but if it does, it will in all probability be rare and of brief duration.

- 1) Previous Explosion Hazard Directive 76/117/EEC was valid until 30.06.2003.
- 2) Previous ElexV 1994 was valid until 30.06.03.



Luminaires are approved for use in explosion hazard zone 22 in accordance with Explosion Hazard Directive 94/9/EC1). Explosion hazard zone 22 in accordance with regulation (EU) 2014/54 (Explosion Protection Regulation): Areas in which an explosive atmosphere due to dust clouds is unlikely to occur, but if it does, it will in all probability be rare and of brief duration.

- 1) Previous Explosion Hazard Directive 76/117/EEC was valid until 30.06.2003.
- 2) Previous ElexV 1994 was valid until 30.06.03.

Certification Symbols



This luminaire has been impact-tested and approved for use in civil defence bunkers. Test certificates are available on request.



Luminaires bearing this symbol are suitable for use on railways and track areas. The maximum angle-dependent luminous intensity values comply with the specifications made by the German Railways.



Luminaire has been tested for impact energy of 10.00 Joules. IK 09 designation according to EN 50102.



This luminaire has been vibration-tested to prove its safety during earthquakes or comparable situations (e.g. required for use in nuclear power plants). Test certificates are available on request.



Luminaires have been tested according to the latest European Standard EN 12 193 (and DIN VDE 0710) to establish their resistance to impacts from flying balls.



Luminaire has been tested for impact energy of 20.00 Joules. IK 10 designation according to EN 50102.



Luminaire is suitable for use in temperatures diverging from those specified by EN 60598.



Luminaire has been tested in accordance with DIN VDE 0710 and found to be ball-proof on tennis courts.



According to EN 60598, luminaires are designed for nominal ambient temperatures of + 25°C. Temporary operation at temperatures of + 35°C is possible.

Luminaire has been tested for impact energy of 2.00 Joules. IK 07 designation according to EN 50102.

Product Technology and Quality Marks



Multi-power operation

Luminaire has been optimised for the operation of varying lamp wattages with respect to lighting technology, glare restriction, temperature, lamp sockets and ballasts. Multiwatt technology stands for interchangeable luminous flux levels within the same luminaire



DALI (Digital Addressable Lighting Interface) is an interface definition for controlling digitally dimmable control gears. Up to 64 DALI units can be operated by one control line. These units can be grouped into no more than 16 overlapping groups. Up to 16 light scenes can be programmed. The protocol definition is specified in the Appendix to EN 60929.



The CE mark exclusively documents compliance with the European directives governing the product. Luminaires are governed by the directives on EMC and low voltages. Compliance with the Directive on Electromagnetic Compatibility presupposes compliance with the standards for radio interference suppression (EN 55015), immunity to interference (EN 61547) and mains pollution (EN 61000-3-2). Compliance with the low-voltage Directive presupposed compliance with the luminaire standard EN 60598 (corresponds with VDE 0711). The manufacturer is responsible for affixing the CE mark and therefore it does not constitute a test mark.



Siteco Savelight

For safety and convenience, protects the luminaire and ensures soft lamp operation.

- Ignitor with digital automatic power-off
- Control gear with thermal protection
- Power reduction (Eco) with integrated timer for starting the lamp at full power



Radio management for transmitting control commands in the 433.42 MHz ISM band.



Symbol for good industrial design. Products bearing the "if" mark have been selected by the IndustrieForum Design Hannover for their outstanding product design.



Luminaire with PF correction as standard or optionally available with PF correction.



The GS symbol is affixed together with the symbol of the authorised testing agency to confirm compliance with German law on appliance safety.



All luminaire packagings used by Siteco Beleuchtungstechnik GmbH can be returned to Interseroh for environmentally compatible disposal.

Installation Instruction Symbols

	Not used for our packagings (see Interseroh).		Hot surfaces near control gear. For example: only suitable cables may be used and must be routed accordingly.		Protective earth connection.
	Recycling symbol of the corrugated cardboard industry.		Luminaire is suitable for use in protected installations outdoors. It must not be exposed to outdoor weathering. X and Y are minimal dimensions for producing over luminaire edge. Indoor luminaires are fundamentally unsuitable for use in unprotected installations outdoors.		Watt rating and number of lamps to be fitted.
	Installation and maintenance may only be carried out by duly qualified personnel.		Note end mark/identification. (No limit stop fitted).		Circuit with PF correction.
	Unplug mains connector before starting any maintenance work.		Sections of the installation instructions bearing this symbol refer to the condition on delivery.		Control gear suitable for specified lamp rating.
	Wear protective gloves (avoid fingerprints).		Further information in the installation instructions for accessory parts.		Capacitance of the PF correction capacitor.
	CAUTION! Pay special attention during installation.		Please note specifications of lamp manufacturers for application of lamps.		Luminaire is suitable for use indoors and in unprotected installations outdoors.
	Luminaires, not for installation in or on normally flammable surfaces, should insulation material surround the luminaire.		Lamp must be approved for use in "open" luminaires. ("open" luminaires also include luminaires with plastic enclosure or with plastic reflector).		
	Precise alignment must be ensured.				

Designation (LBS)	Wattage [Watt]	Cap	Typ. lumen output [lm]	Possible light colours	Colour rendering index	ILCOS	OSRAM	PHILIPS	Havells Sylvania	GE
tubular fluorescent lamps										
T16	14	G5	1200	ww	18	FDH-14/30/18-L/P-G5-16/549	FH 14 W/830 HE	MASTER T15 HE 14W/830	FHE 14W/830	F14W/T5/830
T16	14	G5	1200	nw	18	FDH-14/40/18-L/P-G5-16/549	FH 14 W/840 HE	MASTER T15 HE 14W/840	FHE 14W/840	F14W/T5/840
T16	21	G5	1900	ww	18	FDH-21/30/18-L/P-G5-16/849	FH 21 W/830 HE	MASTER T15 HE 21W/830	FHE 21W/830	F21W/T5/830
T16	21	G5	1900	nw	18	FDH-21/40/18-L/P-G5-16/849	FH 21 W/840 HE	MASTER T15 HE 21W/840	FHE 21W/840	F21W/T5/840
T16	28	G5	2600	ww	18	FDH-28/30/18-L/P-G5-16/1149	FH 28 W/830 HE	MASTER T15 HE 28W/830	FHE 28W/830	F28W/T5/830
T16	28	G5	2600	nw	18	FDH-28/40/18-L/P-G5-16/1149	FH 28 W/840 HE	MASTER T15 HE 28W/840	FHE 28W/840	F28W/T5/840
T16	35	G5	3300	ww	18	FDH-35/30/18-L/P-G5-16/1449	FH 35 W/830 HE	MASTER T15 HE 35W/830	FHE 35W/830	F35W/T5/830
T16	35	G5	3300	nw	18	FDH-35/40/18-L/P-G5-16/1449	FH 35 W/840 HE	MASTER T15 HE 35W/840	FHE 35W/840	F35W/T5/840
T16	24	G5	1750	ww	18	FDH-24/30/18-L/P-G5-16/549	FQ 24 W/830 HO	MASTER T15 HO 24W/830	FHO 24W/830	F24W/T5/830
T16	24	G5	1750	nw	18	FDH-24/40/18-L/P-G5-16/549	FQ 24 W/840 HO	MASTER T15 HO 24W/840	FHO 24W/840	F24W/T5/840
T16	39	G5	3100	ww	18	FDH-39/30/18-L/P-G5-16/849	FQ 39 W/830 HO	MASTER T15 HO 39W/830	FHO 39W/830	F39W/T5/830
T16	39	G5	3100	nw	18	FDH-39/40/18-L/P-G5-16/849	FQ 39 W/840 HO	MASTER T15 HO 39W/840	FHO 39W/840	F39W/T5/840
T16	54	G5	4450	ww	18	FDH-54/30/18-L/P-G5-16/1149	FQ 54 W/830 HO	MASTER T15 HO 54W/830	FHO 54W/830	F54W/T5/830
T16	54	G5	4450	nw	18	FDH-54/40/18-L/P-G5-16/1149	FQ 54 W/840 HO	MASTER T15 HO 54W/840	FHO 54W/840	F54W/T5/840
T16	49	G5	4300	ww	18	FDH-49/30/18-L/P-G5-16/1449	FQ 49 W/830 HO	MASTER T15 HO 49W/830	FHO 49W/830	F49W/T5/830
T16	49	G5	4300	nw	18	FDH-49/40/18-L/P-G5-16/1449	FQ 49 W/840 HO	MASTER T15 HO 49W/840	FHO 49W/840	F49W/T5/840
T16	80	G5	6150	ww	18	FDH-80/30/18-L/P-G5-16/1449	FQ 80 W/830 HO	MASTER T15 HO 80W/830	FHO 80W/830	F80W/T5/830
T16	80	G5	6150	nw	18	FDH-80/40/18-L/P-G5-16/1449	FQ 80 W/840 HO	MASTER T15 HO 80W/840	FHO 80W/840	F80W/T5/840
T26	18	G13	1350	ww	18	FD-18/30/18-E-G13-26/590	L 18 W/830	MASTER TL-D Super 80 18W/830	F18W/830	F18W/830
T26	18	G13	1350	nw	18	FD-18/40/18-E-G13-26/590	L 18 W/840	MASTER TL-D Super 80 18W/840	F18W/840	F18W/840
T26	36	G13	3350	ww	18	FD-36/30/18-E-G13-26/1200	L 36 W/830	MASTER TL-D Super 80 36W/830	F36W/830	F36W/830
T26	36	G13	3350	nw	18	FD-36/40/18-E-G13-26/1200	L 36 W/840	MASTER TL-D Super 80 36W/840	F36W/840	F36W/840
T26	38	G13	3300	ww	18	FD-38/30/18-E-G13-26/1047	L 38 W/830	MASTER TL-D Super 80 38W/830	F38W/830	-
T26	38	G13	3300	nw	18	FD-38/40/18-E-G13-26/1047	L 38 W/840	MASTER TL-D Super 80 38W/840	F38W/840	-
T26	58	G13	5200	ww	18	FD-58/30/18-E-G13-26/1500	L 58 W/830	MASTER TL-D Super 80 58W/830	F58W/830	F58W/830
T26	58	G13	5200	nw	18	FD-58/40/18-E-G13-26/1500	L 58 W/840	MASTER TL-D Super 80 58W/840	F58W/840	F58W/840
Compact fluorescent lamps										
TC-S	9	G23	600	ww	18	FSD-9/30/18-I-G23	DULUX S 9 W/830	MASTER PL-S 9W/830/2P	Lynx-S 9W/830	F9 BX/830 2P G23 GE MIH
TC-S	9	G23	600	nw	18	FSD-9/40/18-I-G23	DULUX S 9 W/840	MASTER PL-S 9W/840/2P	Lynx-S 9W/840	F9BX/SPX41/840 MIH
TC-S	11	G23	900	ww	18	FSD-11/30/18-I-G23	DULUX S 11 W/830	MASTER PL-S 11W/830/2P	Lynx-S 11W/830	F11 BX/830 2P G23 GE MIH
TC-S	11	G23	900	nw	18	FSD-11/40/18-I-G23	DULUX S 11 W/840	MASTER PL-S 11W/840/2P	Lynx-S 11W/840	F11BX/840/2P/S MIH
TC-SEL	11	G27	900	ww	18	FSD-11/30/18-E-G27	DULUX S/E 11 W/830	MASTER PL-S 11W/830/4P	Lynx-SE 11W/830	-
TC-SEL	11	G27	900	nw	18	FSD-11/40/18-E-G27	DULUX S/E 11 W/840	MASTER PL-S 11W/840/4P	Lynx-SE 11W/840	F11BX/840/4P G27 MIH
TC-D	10	G24d-1	600	ww	18	FSQ-10/30/18-I-G24d=1	DULUX D 10 W/830	MASTER PL-C 10W/830/2P	Lynx-D 10W/830	F10DBXT4/SPX30/830
TC-D	10	G24d-1	600	nw	18	FSQ-10/40/18-I-G24d=1	DULUX D 10 W/840	MASTER PL-C 10W/840/2P	Lynx-D 10W/840	F10DBXT4/SPX41/840
TC-D	13	G24d-1	900	ww	18	FSQ-13/30/18-I-G24d=1	DULUX D 13 W/830	MASTER PL-C 13W/830/2P	Lynx-D 13W/830	F13DBXT4/SPX30/830
TC-D	13	G24d-1	900	nw	18	FSQ-13/40/18-I-G24d=1	DULUX D 13 W/840	MASTER PL-C 13W/840/2P	Lynx-D 13W/840	F13DBXT4/SPX41/840
TC-D	18	G24d-2	1200	ww	18	FSQ-18/30/18-I-G24d=2	DULUX D 18 W/830	MASTER PL-C 18W/830/2P	Lynx-D 18W/830	F18DBXT4/SPX30/830
TC-D	18	G24d-2	1200	nw	18	FSQ-18/40/18-I-G24d=2	DULUX D 18 W/840	MASTER PL-C 18W/840/2P	Lynx-D 18W/840	F18DBXT4/SPX41/840
TC-D	26	G24d-3	1800	ww	18	FSQ-26/30/18-I-G24d=3	DULUX D 26 W/830	MASTER PL-C 26W/830/2P	Lynx-D 26W/830	F26DBXT4/SPX30/830
TC-D	26	G24d-3	1800	nw	18	FSQ-26/40/18-I-G24d=3	DULUX D 26 W/840	MASTER PL-C 26W/840/2P	Lynx-D 26W/840	F26DBXT4/SPX41/840
TC-DEL	10	G24q-1	600	ww	18	FSQ-10/30/18-E-G24q=1	DULUX D/E 10 W/830	MASTER PL-C 10W/830/4P	-	F10DBX/SPX30/830/AP
TC-DEL	10	G24q-1	600	nw	18	FSQ-10/40/18-E-G24q=1	DULUX D/E 10 W/840	MASTER PL-C 10W/840/4P	Lynx-DE 10W/840	F10DBX/SPX41/840/AP
TC-DEL	13	G24q-1	900	ww	18	FSQ-13/30/18-E-G24q=1	DULUX D/E 13 W/830	MASTER PL-C 13W/830/4P	-	F13DBX/SPX30/830/AP
TC-DEL	13	G24q-1	900	nw	18	FSQ-13/40/18-E-G24q=1	DULUX D/E 13 W/840	MASTER PL-C 13W/840/4P	Lynx-DE 13W/840	F13DBX/SPX41/840/AP
TC-DEL	18	G24q-2	1200	ww	18	FSQ-18/30/18-E-G24q=2	DULUX D/E 18 W/830	MASTER PL-C 18W/830/4P	-	F18DBX/SPX30/830/AP
TC-DEL	18	G24q-2	1200	nw	18	FSQ-18/40/18-E-G24q=2	DULUX D/E 18 W/840	MASTER PL-C 18W/840/4P	Lynx-DE 18W/840	F18DBX/SPX41/840/AP
TC-DEL	26	G24q-3	1800	ww	18	FSQ-26/30/18-E-G24q=3	DULUX D/E 26 W/830	MASTER PL-C 26W/830/4P	-	F26DBX/SPX30/830/AP
TC-DEL	26	G24q-3	1800	nw	18	FSQ-26/40/18-E-G24q=3	DULUX D/E 26 W/840	MASTER PL-C 26W/840/4P	Lynx-DE 26W/840	F26DBX/SPX41/840/AP
TC-T	26	GX24d-3	1800	ww	18	FSM-26/30/18-I-GX24d=3	DULUX T 26 W/830 PLUS	MASTER PL-T 26W/830/2P	Lynx-T 26W/830	F26TBX/SPX30/830/A/2P
TC-T	26	GX24d-3	1800	nw	18	FSM-26/40/18-I-GX24d=3	DULUX T 26 W/840 PLUS	MASTER PL-T 26W/840/2P	Lynx-T 26W/840	F26TBX/SPX41/840/A/2P
TC-TEL	18	GX24q-2	1200	ww	18	FSMH-18/30/18-I-GX24q=2	DULUX T/E 18 W/830 PLUS	MASTER PL-T 18W/830/4P	Lynx-TE FSD 18W/830	F18TBX/830/A/4P/EOL
TC-TEL	18	GX24q-2	1200	nw	18	FSMH-18/40/18-I-GX24q=2	DULUX T/E 18 W/840 PLUS	MASTER PL-T 18W/840/4P	Lynx-TE FSD 18W/840	F18TBX/SPX41/840/A/4P
TC-TEL	26	GX24q-3	1800	ww	18	FSMH-26/30/18-I-GX24q=3	DULUX T/E 26 W/830 PLUS	MASTER PL-T 26W/830/4P	Lynx-TE FSD 26W/830	F26TBX/SPX30/830/A/4P
TC-TEL	26	GX24q-3	1800	nw	18	FSMH-26/40/18-I-GX24q=3	DULUX T/E 26 W/840 PLUS	MASTER PL-T 26W/840/4P	Lynx-TE FSD 26W/840	F26TBX/SPX41/840/A/4P
TC-TEL	32	GX24q-3	2400	ww	18	FSMH-32/30/18-I-GX24q=3	DULUX T/E 32 W/830 PLUS	MASTER PL-T 32W/830/4P	Lynx-TE FSD 32W/830	F32TBX/SPX30/830/AP4P
TC-TEL	32	GX24q-3	2400	nw	18	FSMH-32/40/18-I-GX24q=3	DULUX T/E 32 W/840 PLUS	MASTER PL-T 32W/840/4P	Lynx-TE FSD 32W/840	F32TBX/SPX41/840/A/4P
TC-TEL	42	GX24q-4	3200	ww	18	FSMH-42/30/18-I-GX24q=4	DULUX T/E 42 W/830 PLUS	MASTER PL-T 42W/830/4P	Lynx-TE FSD 42W/830	F42TBX/830/A/4P/EOL
TC-TEL	42	GX24q-4	3200	nw	18	FSMH-42/40/18-I-GX24q=4	DULUX T/E 42 W/840 PLUS	MASTER PL-T 42W/840/4P	Lynx-TE FSD 42W/840	F42TBX/841/A/4P/EOL
TC-TEL	57	GX24q-5	4300	ww	18	FSMH-57/30/18-E-GX24q=5	-	MASTER PL-T 57W/830/4P	-	-
TC-TEL	57	GX24q-5	4300	nw	18	FSMH-57/40/18-E-GX24q=5	-	MASTER PL-T 57W/840/4P	-	-
TC-TELI	60	G28-1	4000	ww	18	FSM6H-60/30/18-L/P-2G8=1	-	MASTER PL-H 60W/830/4P	-	-
TC-TELI	60	G28-1	4000	nw	18	FSM6H-60/40/18-L/P-2G8=1	-	MASTER PL-H 60W/840/4P	-	-
TC-TELI	85	G28-1	6000	ww	18	FSM6H-85/30/18-L/P-2G8=1	-	MASTER PL-H 85W/830/4P	-	-
TC-TELI	85	G28-1	6000	nw	18	FSM6H-85/40/18-L/P-2G8=1	-	MASTER PL-H 85W/840/4P	-	-
TC-TELI	120	G28-1	9000	ww	18	FSM-8H-120/30/18-L/P-2G8=1	DULUX 120 W HO CONSTANT/830	MASTER PL-H 120W/830/4P	-	-
TC-TELI	120	G28-1	9000	nw	18	FSM-8H-120/40/18-L/P-2G8=1	DULUX 120 W HO CONSTANT/840	MASTER PL-H 120W/840/4P	-	-
TC-L	18	G211	1200	ww	18	FSD-18/30/18-E-2G11	DULUX L 18 W/830	MASTER PL-L 18W/830/4P	Lynx-L 18W/830	F18BX/830
TC-L	18	G211	1200	nw	18	FSD-18/40/18-E-2G11	DULUX L 18 W/840	MASTER PL-L 18W/840/4P	Lynx-L 18W/840	F18BX/840
TC-L	24	G211	1800	ww	18	FSD-24/30/18-E-2G11	DULUX L 24 W/830	MASTER PL-L 24W/830/4P	Lynx-L 24W/830	F24BX/830
TC-L	24	G211	1800	nw	18	FSD-24/40/18-E-2G11	DULUX L 24 W/840	MASTER PL-L 24W/840/4P	Lynx-L 24W/840	F24BX/840
TC-L	36	G211	2900	ww	18	FSD-36/30/18-E-2G11	DULUX L 36 W/830	MASTER PL-L 36W/830/4P	Lynx-L 36W/830	F36BX/830
TC-L	36	G211	2900	nw	18	FSD-36/40/18-E-2G11	DULUX L 36 W/840	MASTER PL-L 36W/840/4P	Lynx-L 36W/840	F36BX/840
TC-L	40	G211	3500	ww	18	FSDH-40/30/18-2G11	DULUX L 40 W/830	MASTER PL-L 40W/830/4P	Lynx-LE 40W/830	F40BX/830
TC-L	40	G211	3500	nw	18	FSDH-40/40/18-2G11	DULUX L 40 W/840	MASTER PL-L 40W/840/4P	Lynx-LE 40W/840	F40BX/840
TC-L	55	G211	4800	ww	18	FSDH-55/30/18-2G11	DULUX L 55 W/830	MASTER PL-L 55W/830/4P	Lynx-LE 55W/830	F55BX/830 GE 25WAY
TC-L	55	G211	4800	nw	18	FSDH-55/40/18-2G11	DULUX L 55 W/840	MASTER PL-L 55W/840/4P	Lynx-LE 55W/840	F55BX/840 GE 25WAY
TC-L	80	G211	3500	ww	18	FSDH-80/30/18-2G11	DULUX L 80 W/830	MASTER PL-L 80W/830/4P	-	-
TC-L	80	G211	3500	nw	18	FSDH-80/40/18-2G11	DULUX L 80 W/840	MASTER PL-L 80W/840/4P	-	-

Designation (LBS)	Wattage [Watt]	Cap	Typ. lumen output [lm]	Possible light colours	Colour rendering index	ILCOS	OSRAM	PHILIPS	Havells Sylvania	GE
Discoid fluorescent lamps										
TCR-TSE flat	6	GX53	220	ww	1B	–	–	–	Micro-Lynx F 6W/827	–
TCR-TSE flat	6	GX53	220	ww	1B	–	–	–	Micro-Lynx F 6W/830	–
TCR-TSE flat	6	GX53	220	nw	1B	–	–	–	Micro-Lynx F 6W/840	–
Circular fluorescent lamps										
T16-R Constant	22	2GX13	1800	ww	1B	F5CH-22/30/1B-L/P-2GX13-16	–	MASTER TL5 Circular 22W/830	–	–
T16-R Constant	22	2GX13	1800	nw	1B	F5CH-22/40/1B-L/P-2GX13-16	–	MASTER TL5 Circular 22W/840	–	–
T16-R Constant	40	2GX13	3300	ww	1B	F5CH-40/30/1B-L/P-2GX13-16	–	MASTER TL5 Circular 40W/830	–	–
T16-R Constant	40	2GX13	3300	nw	1B	F5CH-40/40/1B-L/P-2GX13-16	–	MASTER TL5 Circular 40W/840	–	–
T16-R Constant	55	2GX13	4200	ww	1B	F5CH-55/30/1B-L/P-2GX13-16	–	MASTER TL5 Circular 55W/830	–	–
T16-R Constant	55	2GX13	4200	nw	1B	F5CH-55/40/1B-L/P-2GX13-16	–	MASTER TL5 Circular 55W/840	–	–
T16-R	22	2GX13	1800	ww	1B	FC-22/30/1B-E-2GX13-16	FC 22 W/830	–	–	–
T16-R	22	2GX13	1800	nw	1B	FC-22/40/1B-E-2GX13-16	FC 22 W/840	–	–	–
T16-R	40	2GX13	3200	ww	1B	FC-40/30/1B-E-2GX13-16	FC 40 W/830	–	–	–
T16-R	40	2GX13	3200	nw	1B	FC-40/40/1B-E-2GX13-16	FC 40 W/840	–	–	–
T16-R	55	2GX13	4200	ww	1B	FC-55/30/1B-E-2GX13-16	FC 55 W/830	–	–	–
T16-R	55	2GX13	4200	nw	1B	FC-55/40/1B-E-2GX13-16	FC 55 W/840	–	–	–
Fluorescent lamps with looped bulb										
TC-DD	16	GR8	1050	ww	1B	F5S-16/27/1B-I-GR8	CFL SQUARE 16 W/827 2-Pin	PL-Q 16W/827/2P	–	F162D/827 GE 20PK
TC-DD	16	GR8	1050	ww	1B	F5S-16/30/1B-I-GR8	–	PL-Q 16W/830/2P	–	–
TC-DD	16	GR8	1050	nw	1B	F5S-16/35/1B-I-GR8	CFL SQUARE 16 W/835 2-Pin	–	–	F162D/835 GE 20PK
TC-DD	16	GR8	1050	tw	1B	F5S-16/60/1B-I-GR8	–	–	–	F162D/860 GE 20PK
Metal halide lamps with ellipsoid bulb and quartz discharge tube										
HIE	70	E27	4700	ww	1B	MES/UB-70/30/1B-H-E27-55/144	HQI-E 70/WDL	–	HSI-MP 70W CO 3K E27	–
HIE	70	E27	5100	nw	1B	MES/UB-70/38/1B-H-E27-55/144	HQI-E 70/NDL	–	HSI-MP 70W CO 4K E27	–
HIE	100	E27	7900	ww	1B	MES/UB-100/29/1B-H-E27-55/144	HQI-E 100/WDL	–	HSI-MP 100W CO 3K E27	–
HIE	100	E27	7700	nw	1B	MES/UB-100/38/1B-H-E27-55/144	HQI-E 100/NDL	–	HSI-MP 100W CO 4K E27	–
HIE	150	E27	11600	ww	1B	MES/UB-150/29/1B-H-E27-55/144	HQI-E 150/WDL	–	HSI-MP 150W CO 3K E27	–
HIE	150	E27	11500	nw	1B	MES/UB-150/38/1B-H-E27-55/144	HQI-E 150/NDL	–	HSI-MP 150W CO 4K E27	–
HIE	250	E40	18000	nw	2A	ME-250/45/2A-H-E40-V	–	MASTER HPI Plus 250W/745 BU E40	Britelux HSI-SX 250W/CO/P	–
HIE	250	E40	17000	tw	1A	MES/UB-250/52/1A-H-E40-90/226	HQI-E/P 250/D	–	–	–
HIE	250	E40	19000	tw	1A	ME/UB-250/52/1A-H-E40-90/226	HQI-E 250/D	–	–	–
HIE	250	E40	17000	tw	1A	ME/UB-250/60/1A-H-E40-90/226	–	–	–	ARC250/D/H/960/E40
HIE	250	E40	18000	tw	2A	ME-250/67/2A-H-E40-90/225/V	–	MASTER HPI Plus 250W/767 BU E40	–	–
HIE	400	E40	40000	nw	2B	ME/UB-400/46/2B-H-E40-120/285/H45	HQI-E 400/N	–	Britelux HSI-SX 400W/CO/P	–
HIE	400	E40	32500	nw	2A	ME-400/45/2A-H-E40-V	–	MASTER HPI Plus 400W/745 BU E40	–	–
HIE	400	E40	31000	tw	1A	MES/UB-400/45/1A-H-E40-120/290	HQI-E/P 400/D	–	–	–
HIE	400	E40	34000	tw	1A	ME/UB-400/59/1A-H-E40-120/290	HQI-E 400/D	–	–	–
HIE	400	E40	32500	tw	2A	ME-400/67/2A-H-E40-90/225/V	–	MASTER HPI Plus 400W/767 BU E40	–	–
HIE	1000	E40	100000	nw	2B	ME-1000/37/2B-H-E40-165/380/H45	HQI-E 1000/N	–	–	–
Metal halide lamps with ellipsoid bulb and ceramic discharge tube										
HIE-CE	70	E27	6400	ww	1B	MES/UB-70/30/1B-H-E27-54/138	HCI-E/P 70/830 WDL PB coated	MASTER CityWhite CDO-ET 70W/828 E27	–	CMH70/E/UVC/U/830/E27/D
HIE-CE	70	E27	6000	nw	1A	MES/UB-70/42/1A-H-E27-54/138	HCI-E/P 70/942 NDL PB coated	–	–	–
HIE-CE	100	E27	8500	ww	1B	MES/UB-100/30/1B-H-E27-54/138	HCI-E/P 100/830 WDL PB coated	–	–	CMH100/E/UVC/U/830/E27/D
HIE-CE	100	E27	8300	nw	1A	MES/UB-100/42/1A-H-E27-54/138	HCI-E/P 100/942 NDL PB coated	–	–	–
HIE-CE	150	E27	13300	ww	1B	MES/UB-150/30/1B-H-E27-54/138	HCI-E/P 150/830 WDL PB coated	–	–	–
HIE-CE	150	E27	13300	nw	1A	MES/UB-150/42/1A-H-E27-54/138	HCI-E/P 150/942 NDL PB coated	–	–	–
HIE-CE	250	E40	24500	ww	1B	ME/UB-250/30/1B-H-E40-90/226	HCI-E 250/830 WDL PB	–	–	–
HIE-CE	250	E40	24500	nw	1A	ME/UB-250/42/1A-H-E40-90/226	HCI-E 250/830 NDL PB	–	–	–
Metal halide lamps with tubular bulb and ceramic discharge tube										
HIT-TC-CE	20	PGJ5	1650	ww	1B	MC-20/30/1B-H-PGJ5	–	CDM-Tm Mini 20W/830	–	–
HIT-TC-CE	35	PGJ5	3000	ww	1A	MC-35/30/1A-H-PGJ5	–	CDM-Tm Mini 35W/930	–	–
HIT-TC-CE	20	GU6,5	1700	ww	1B	MT/UB-20/30/1B-H-E-GU6,5-13/57	HCI-TF 20/830 WDL PB	–	–	CMH20/T/UVC/830/GU6,5
HIT-TC-CE	20	G8,5	1700	ww	1B	MT/UB-20/30/1B-H-E-G8,5-15/81	HCI-TF 20/830 WDL PB	–	–	CMH20/TC/UVC/830/G8,5
HIT-TC-CE	35	G8,5	3000	ww	1A	MT/UB-35/30/1A-H-G8,5-15/81	HCI-TF 35/930 WDL PB	MASTERColour CDM-TC 70W/830 G12	–	–
HIT-TC-CE	35	G8,5	3400	ww	1B	MT/UB-35/30/1B-H-G8,5-15/81	HCI-TF 35/830 WDL PB	MASTERColour CDM-TC 35W/830 G8,5	CMi-TC 35W/WDL UVS	CMH35/TC/UVC/U/830/G8,5
HIT-TC-CE	35	G8,5	3200	nw	1A	MT/UB-35/42/1A-H-G8,5-15/81	HCI-TF 35/942 NDL PB	MASTERColour CDM-TC 35W/942 G8,5	–	–
HIT-TC-CE	70	G8,5	6300	ww	1A	MT/UB-70/30/1A-H-G8,5-15/81	HCI-TF 70/930 WDL PB	MASTERColour CDM-TC Elite 70W/930 G8,5	–	–
HIT-TC-CE	70	G8,5	6900	ww	1B	MT/UB-70/30/1B-H-G8,5-15/81	HCI-TF 70/830 WDL PB	MASTERColour CDM-TC 70W/830 G8,5	CMi-TC 70W/WDL UVS	CMH70/TC/UVC/U/830/G8,5
HIT-TC-CE	70	G8,5	5900	nw	1A	MT/UB-70/42/1A-H-G8,5-15/81	–	MASTERColour CDM-TC 70W/942 G8,5	–	–
HIT-CE	35	G12	3100	ww	1A	MT/UB-35/30/1A-H-G12-19/100	HCI-T 35/930 WDL PB	MASTERColour CDM-T Elite 35W/930 G12	–	–
HIT-CE	35	G12	3400	ww	1B	MT/UB-35/30/1B-H-G12-19/100	HCI-T 35/830 WDL PB	MASTERColour CDM-T 35W/830 G12	CMi-T 35W/WDL UVS	CMH35/T/UVC/U/830/G12
HIT-CE	35	G12	3300	nw	1A	MT/UB-35/42/1A-H-G12-19/100	HCI-T 35/942 NDL PB	MASTERColour CDM-T 35W/942 G12	–	–
HIT-CE	70	G12	6400	ww	1A	MT/UB-70/30/1A-H-G12-19/100	HCI-T 70/930 WDL PB	MASTERColour CDM-T Elite 70W/930 G12	–	–
HIT-CE	70	G12	7000	ww	1B	MT/UB-70/30/1B-H-G12-19/100	HCI-T 70/830 WDL PB	MASTERColour CDM-T 70W/830 G12	CMi-T 70W/WDL UVS	CMH70/T/UVC/U/830/G12
HIT-CE	70	G12	6700	nw	1A	MT/UB-70/42/1A-H-G12-19/100	HCI-T 70/942 NDL PB	MASTERColour CDM-T 70W/942 G12	CMi-T 70W/NDL UVS	CMH70/T/UVC/U/942/G12
HIT-CE	150	G12	15500	ww	1B	MT/UB-150/30/1B-H-G12-25/105	HCI-T 150/830 WDL PB	MASTERColour CDM-T 150W/830 G12	CMi-T 150W/WDL UVS	CMH150/T/UVC/U/830/G12
HIT-CE	150	G12	14500	nw	1A	MT/UB-150/42/1A-H-G12-25/105	HCI-T 150/942 NDL PB	MASTERColour CDM-T 150W/942 G12	CMi-T 150W/NDL UVS	CMH150/T/UVC/U/942/G12
HIT-CE	70	E27	6300	ww	1B	MT-70/28/1B-H-E27	–	MASTER CityWhite CDO-TT 70W/828 E27	–	–
HIT-CE	70	E27	6400	nw	1A	MT-70/42/1A-H-E27	–	MASTERColour CDM-TT 70W/942 E27	–	–
HIT-CE	150	E40	13500	ww	1B	MT-150/28/1B-H-E40	–	MASTER CityWhite CDO-TT 150W/828 E40	–	–
HIT-CE	150	E40	12000	nw	1A	MT-150/42/1A-H-E40	–	MASTERColour CDM-TT 150W/942 E40	–	–
HIT-CE	250	E40	25800	ww	1B	MT/UB-250/30/1B-H-E40-46/226	HCI-T 250/830 WDL PB	MASTER City White CDO-TT 250W/828	–	CMH250/TT/UVC/U/830/E40
HIT-CE	250	E40	25000	nw	1A	MT/UB-250/42/1A-H-E40-46/226	HCI-T 250/942 NDL PB	–	–	–
HIT-CE	400	E40	42000	ww	1B	MT/UB-400/30/1B-H-E40	–	–	–	MH400/TT/UVC/VBU/830/E40
HIT-CE-od	45	PGZ12	4300	ww	2B	MT-45/28/2B-H-PGZ12	–	MASTER CosmoWhite CPO-TW 45W/628 PGZ12	–	–
HIT-CE-od	60	PGZ12	6850	ww	2A	MT-60/28/2A-H-PGZ12	–	MASTER CosmoWhite CPO-TW 60W/728 PGZ12	–	–
HIT-CE-od	90	PGZ12	10450	ww	2A	MT-90/28/2A-H-PGZ12	–	MASTER CosmoWhite CPO-TW 90W/728 PGZ12	–	–
HIT-CE-od	140	PGZ12	16500	ww	2A	MT-140/28/2A-H-PGZ12	–	MASTER CosmoWhite CPO-TW 140W/728 PGZ12	–	–

Designation (LBS)	Wattage [Watt]	Cap	Typ. lumen output [lm]	Possible light colours	Colour rendering index	ILCOS	OSRAM	PHILIPS	Havells Sylvania	GE
Metal halide lamps with tubular bulb and quartz discharge tube										
HIT	250	E40	20500	nw	2B	MT-250/45/2B-H-E40-/H	–	MASTER HPI-T Plus 250W/645 E40	HSI-THX 250W	ARC250/T/H/742/E40
HIT	250	E40	20000	tw	1A	MT-250/53/1A-H-E40	–	–	HSI-T 250W / 6K	ARC250/T/NBU/960/E40
HIT	400	E40	35000	tw	1A	MC/UB-400/52/1A-H-E40-62/285	HQI-BT 400/D	–	HSI-T 400W / 6K	KRC400/T/H/960/E40
HIT	400	E40	35000	nw	2B	MT-400/45/2B-H-E40-/H	–	MASTER HPI-T Plus 400W/645 E40	Britelux HSI-TSX 400W	ARC400/T/H/742/E40
HIT	400	E40	42000	nw	2B	MT/UB-400/35/2B-H-E40-46/273/P45	HQI-T 400/N	–	–	–
HIT	1000	E40	110000	nw	2B	MT-1000/35/2B-H-E40-76/345/P30	HQI-T 1000/N	–	–	–
HIT	1000	E40	85000	nw	2B	MT-1000/43/2B-H-E40-/H	–	HPI-T Pro 1000W/643 E40 220V	HSI-T 1000W/4K	–
HIT	1000	E40	85000	tw	1A	MT-1000/60/1A-H-E40-76/340/P30	HQI-T 1000/D	–	–	–
HIT	2000	E40	240000	nw	2B	MT-2000/40/2B-E-E40-100/430/P60	HQI-T 2000/N/E SUPER	–	HSI-T 2000W-S4K 380V/I	SPL2000/I/T/H/640/E40
HIT	2000	E40	240000	nw	2B	MT-2000/40/2B-E-E40-100/430/P60	HQI-T 2000/N/SN/ SUPER	–	HSI-T 2000W-S4K 380V	–
HIT	2000	E40	220000	nw	2B	MT-2000/45/2B-E-E40-100/430/P30	HQI-T 2000/N/230 V	–	–	–
HIT	2000	E40	200000	nw	2B	MT-2000/45/2B-E/I-E40-100/430/P60	HQI-T 2000/N	HPI-T 2000W/646 E40 220V	–	–
HIT	2000	E40	180000	tw	1A	MT-2000/60/1A-E-E40-100/430/P30	HQI-T 2000/D	–	–	HGM2000W/D1
HIT	2000	E40	180000	tw	1A	MT-2000/60/1A-E/I-E40-100/430/P30	HQI-T 2000/D/I	–	–	HGMIG2000W/D
Metal halide lamps with tubular bulb and ceramic discharge tube										
HIT-DE-CE	70	RX7s	6700	nw	1A	MD/UB-70/42/1A-H-RX7s-21/114,2/P45	HCI-TS 70/942 NDL PB	MASTERColour CDM-TD 70W/942 RX7s	CMi-TD 70W/NDL UVS	CMH70/TD/UVC/942/RX7S
HIT-DE-CE	150	RX7s-24	14800	ww	1B	MD/UB-150/30/1B-H-RX7s-24-24/132/P45	HCI-TS 150/830 WDL PB	MASTERColour CDM-TD 150W/830 RX7s	CMi-TD 150W/WDL UVS	–
HIT-DE-CE	150	RX7s-24	14200	nw	1A	MD/UB-150/42/1A-H-RX7s-24-24/132/P45	HCI-TS 150/942 NDL PB	MASTERColour CDM-TD 150W/942 RX7s	CMi-TD 150W/NDL UVS	CMH150/TD/UVC/942/RX7S-24
HIT-DE-CE	250	Fc2	25000	ww	1B	MD/UB-250/30/1B-H-Fc2-25/163/P45	HCI-TS 250/830 WDL PB	–	–	–
HIT-DE-CE	250	Fc2	23000	nw	1A	MD/UB-250/42/1A-H-Fc2-25/163/P45	HCI-TS 250/942 NDL PB	–	–	–
Metal halide lamps with tubular bulb and quartz discharge tube										
HIT-DE	400	Fc2	36000	nw	1B	MD/UB-400/42/1B-H-Fc2-31/206/P45	HQI-TS 400/NDL	–	–	–
HIT-DE	400	Fc2	37000	tw	1A	MD/UB-400/52/1A-H-Fc2-31/206/P45	HQI-TS 400/D	–	–	–
HIT-DE	1000	Kabel	90000	nw	1B	MN-1000/44/1B-H-Kabelschuh-36/187/P15	HQI-TS 1000/NDL/S	–	–	–
HIT-DE	1000	Kabel	90000	tw	1A	MN-1000/59/1A-H-Kabelschuh-36/187/P15	HQI-TS 1000/D/S	–	–	–
HIT-DE	2000	Kabel	200000	tw	1A	MN-2000/58/1A-E-Kabelschuh-36/187/P15	HQI-TS 2000/D/S	MHN-SB 2000W/956 400V K12s-7	HSI-TD 2000W/D	–
HIT-DE	2000	Kabel	200000	nw	1B	–	HQI-TS 2000/NDL/S	–	–	–
HIT-DE Longarc	2000	Kabel	230000	nw	2B	MN-2000/41/2B-E-Kabelschuh-32/268/P15	HQI-TS 2000/N/L	–	–	–
Mercury lamps with ellipsoid bulb										
HME	50	E27	1600	ww	2B	QE/R-50/30/2B-H-E27-55/130	HQL 50 Super De Luxe	–	HSL-SC 50 W	–
HME	50	E27	2000	ww	3	QE/R-50/33/3-H-E27-55/130	HQL 50 De Luxe	HPL 4 50W/634 E27 SG	–	H50DX/27
HME	50	E27	1800	nw	3	QE/R-50/42/3-H-E27-55/130	HQL 50	HPL 4 50W/642 E27 SG	HSL-BW 50 W	H50/27
HME	80	E27	3400	ww	2B	QE/R-80/30/2B-H-E27-70/156	HQL 80 Super De Luxe	–	HSL-SC 80W E27	–
HME	80	E27	4000	ww	3	QE/R-80/32/3-H-E27-70/156	HQL 80 De Luxe	HPL 4 80W/634 E27 SG	–	H80DX/27
HME	80	E27	3800	nw	3	QE/R-80/41/3-H-E27-70/156	HQL 80	HPL 4 80W/642 E27 SG	HSL-BW 80W E27	H80/27
HME	125	E27	5700	ww	2B	QE/R-125/30/2B-H-E27-75/170	HQL 125 Super De Luxe	–	HSL-SC 125W E27	–
HME	125	E27	6800	ww	3	QE/R-125/32/3-H-E27-75/170	HQL 125 De Luxe	HPL 4 125W/634 E27 SG	–	H125DX/27
HME	125	E27	6300	nw	3	QE/R-125/40/3-H-E27-75/170	HQL 125	HPL 4 125W/642 E27 SG	HSL-BW 125W E27	H125/27
HME	250	E40	14000	ww	3	QE/R-250/31/3-H-E40-90/226	HQL 250 De Luxe	HPL Comfort 250W E40 HG	HSL-SC 250W E40	–
HME	250	E40	13000	ww	3	QE/R-250/33/3-H-E40-90/226	–	–	–	H250DX/40
HME	250	E40	13000	nw	3	QE/R-250/39/3-H-E40-90/226	HQL 250	HPL-N 250W/542 E40 HG	HSL-BW 250W E40	H250/40
HME	400	E40	24000	ww	3	QE/R-400/30/3-H-E40-120/290	HQL 400 De Luxe	HPL-Comfort 400 W HG	–	–
HME	400	E40	22000	ww	3	QE/R-400/30/3-H-E40-120/290	HQL 400	–	–	–
HME	400	E40	24200	nw	3	QE-400/35/3-H-E40	–	HPL Comfort 400W E40 HG	HSL-SC 400W E40	H400DX/40
HME	400	E40	22000	nw	3	QE-400/40/3-H-E40	–	HPL-N 400W/542 E40 HG	HSL-BW 400W E40	H400/40
HME	1000	E40	57000	nw	3	QE/R-1000/35/3-H-E40-165/355	HQL 1000	–	–	–
HME	1000	E40	58500	nw	4	QE-1000/39/4-H-E40	–	HPL-N 1000W/542 E40 HG	HSL-BW 1000W E40	–
High pressure sodium lamps with ellipsoid bulb										
HSE-I	50	E27	3500	ww	4	SE-50/20/4-H/I-E27-70/156	NAV-E 50/I	SON 50W/220 I E27	SHP 50W/CO-I	LU50/90/I/27 MIH
HSE-I	70	E27	5600	ww	4	SE-70/20/4-H/I-E27-70/156	NAV-E 70/I	SON 70W/220 I E27	SHP 70W/CO-I	LU70/90/I/27 MIH
HSE	50	E 27	3500	ww	4	SE-50/20/4-H-E27-70/156	NAV-E 50/E	MASTER SON PIA 50W/220 E27	SHP-S 50W/CO-E	LU50/90/SBY/D/27 MIH
HSE	70	E 27	5600	ww	4	SE-70/20/4-H-E27-70/156	NAV-E 70/E	MASTER SON PIA 70W/220 E27	SHP-S 70W/CO-E	LU70/90/SBY/D/27 MIH
HSE	100	E40	10200	ww	4	SE-100/20/4-H-E40-75/186	NAV-E 100 SUPER 4Y	MASTER SON PIA Plus 100W/220 E40	SHP-S 100W	LU100/100/MO/D/40
HSE	150	E40	17000	ww	4	SE-150/20/4-H-E40-90/226	NAV-E 150 SUPER 4Y	MASTER SON PIA Plus 150W/220 E40	SHP-S 150W	LU150/100/SBY/D/40 MIH
HSE	250	E40	31100	ww	4	SE-250/20/4-H-E40-90/226	NAV-E 250 SUPER 4Y	MASTER SON PIA Plus 250W/220 E40	SHP-S 250W	LU250/SBY/D/40 MIH
HSE	400	E40	55500	ww	4	SE-400/20/4-H-E40-120/290	NAV-E 400 SUPER 4Y	MASTER SON PIA Plus 400W/220 E40	SHP-S 400W	LU400/SBY/D/40 MIH
HSE	1000	E40	120000	ww	4	SE-1000/20/4-H-E40-165/370	NAV-E 1000	SON 1000W/220 E40	–	LU1000/110/D/40 MIH
High pressure sodium lamps with tubular bulb										
HST	50	E27	4400	ww	4	ST-50/20/4-H-E27-37/156	NAV-T 50 SUPER 4Y	MASTER SON-T PIA Plus 50W/220	SHP-TS 50W	LU50/90/SBY/T/27 MIH
HST	70	E27	6600	ww	4	ST-70/20/4-H-E27-37/156	NAV-T 70 SUPER 4Y	MASTER SON-T PIA Plus 70W/220 E27	SHP-TS 70W	LU70/90/SBY/T12/27 MIH
HST	100	E40	10700	ww	4	ST-100/20/4-H-E40-46/211	NAV-T 100 SUPER 4Y	MASTER SON-T PIA Plus 100W/220 E40	SHP-TS 100W	LU100/100/MO/SBY/T/40
HST	150	E40	17500	ww	4	ST-150/20/4-H-E40-46/211	NAV-T 150 SUPER 4Y	MASTER SON-T PIA Plus 150W/220 E40	SHP-TS 150W	LU150/100/SBY/T/40 MIH
HST	250	E40	33200	ww	4	ST-250/20/4-H-E40-46/257	NAV-T 250 SUPER 4Y	MASTER SON-T PIA Plus 250W/220 E40	SHP-TS 250W	LU250/SBY/T/40 MIH
HST	400	E40	56500	ww	4	ST-400/20/4-H-E40-46/285	NAV-T 400 SUPER 4Y	MASTER SON-T PIA Plus 400W/220 E40	SHP-TS 400W	LU400/SBY/T/40 MIH
HST	1000	E40	130000	ww	4	ST-1000/20/4-H-E40-65/355	NAV-T 1000	SON-T 1000W/220 E40	SHP-T 1000W	TU LU1000/110/T/40 4PK GE MIH
HST-DE	70	RX7s	6800	ww	4	SD-70/20/4-H-RX7s-20/114,2/P45	NAV-TS 70 SUPER 4Y	–	SHP - TD 70W	–
HST-DE	150	RX7s-24	15000	ww	4	SD-150/20/4-H-RX7s-24-23/132/P45	NAV-TS 150 SUPER 4Y	–	SHP - TD 150W	–
HST-DE	250	Fc2	25000	ww	4	SD-250/20/4-H-Fc2-23/206/P45	NAV-TS 250	–	–	–
HST-DE	400	Fc2	48000	ww	4	SD-400/20/4-H-Fc2-23/206/P45	NAV-TS 400	–	–	–
HST-CRI	50	CX12-1	2400	ww	1B	STH-50/25/1B-CX12-1	–	MASTER SDW-TG Mimi 50W/825 CX12-1	–	–
HST-CRI	100	CX12-1	4900	ww	1B	STH-100/25/1B-CX12-1	–	MASTER SDW-TG Mimi 100W/825 CX12-1	–	–

Designation (LBS)	Wattage [Watt]	Cap	Typ. lumen output [lm]	Possible light colours	Colour rendering index	ILCOS	OSRAM	PHILIPS	Havells Sylvania	GE
Low voltage halogen incandescent lamps										
QT LP ax 12	20	GY6.35	320	ww	1A	HSGST/UB-20-12-GY6.35-15	64427S	Capsuleline 20W GY6.35 12V CL 4000h	–	M76/Q20/GY6.35
QT LP ax 12	20	GY6.35	420	ww	1A	HSG/F-20-12-GY6.35	–	MASTERCapsule 20W GY6.35 12V IR	–	–
QT LP ax 12	25	GY6.35	500	ww	1A	HSGST/UB/IB-25-12-GY6.35	64429 IRC	–	–	–
QT LP ax 12	30	GY6.35	750	ww	1A	HSG/F-30-12-GY6.35	–	MASTERCapsule 30W GY6.35 12V IR	–	–
QT LP ax 12	35	GY6.35	600	ww	1A	HSGST/UB-35-12-GY6.35-15	64432S	Capsuleline 35W GY6.35 12V CL 4000h	Capsule 12V/35W	M75/Q35/GY6.35
QT LP ax 12	35	GY6.35	900	ww	1A	HSGST/UB/IB-35-12-GY6.35	64432 IRC	–	–	–
QT LP ax 12	40	GY6.35	1250	ww	1A	HSG/F-45-12-GY6.35	–	MASTERCapsule 45W GY6.35 12V IR	–	–
QT LP ax 12	50	GY6.35	910	ww	1A	HSGST/UB-50-12-GY6.35-15	64440S	Capsuleline 50W GY6.35 12V CL 4000h	Capsule 12V/50W	M74/Q50/GY6.35
QT LP ax 12	50	GY6.35	1250	ww	1A	HSGST/UB/IB-50-12-GY6.35	64440 IRC	–	–	–
QT LP ax 12	60	GY6.35	1700	ww	1A	HSG/F-60-12-GY6.35	–	MASTERCapsule 60W GY6.35 12V IR	–	–
QT LP ax 12	65	GY6.35	1700	ww	1A	HSGST/UB/IB-65-12-GY6.35	64447 IRC	–	–	–
QT LP ax 12	75	GY6.35	1450	ww	1A	HSGST/UB-75-12-GY6.35-15	64450S	Capsuleline 75W GY6.35 12V CL 4000h	Capsule 12V/75W	M73/Q75/GY6.35
QT LP ax 12	90	GY6.35	1800	ww	1A	HSGST/UB-90-12-GY6.35-15	64458S	–	–	–
QT LP ax 12	100	GY6.35	2200	ww	1A	HSG/C/UB-100-12-GY6.35	–	Capsuleline 100W GY6.35 12V CL 4000h	Capsule 12V/100W	M180/Q100/GY6.35
Low voltage halogen incandescent lamps with reflector										
QR-CBC51/8° IRC	20	GU5.3	–	ww	1A	HRGS/UB/IB 20-12-GU5.3-51/8	–	MASTERLine ES 20W GU5.3 12V 8D	–	–
QR-CBC51/10° IRC	20	GU5.3	–	ww	1A	HRGS/UB/IB 20-12-GU5.3-51/10	48860SP	–	–	–
QR-CBC51/24° IRC	20	GU5.3	–	ww	1A	HRGS/UB/IB 20-12-GU5.3-51/24	48860FL	–	–	–
QR-CBC51/36° IRC	20	GU5.3	–	ww	1A	HRGS/UB/IB 20-12-GU5.3-51/36	48860WFL	MASTERLine ES 20W GU5.3 12V 36D	–	–
QR-CBC51/60° IRC	20	GU5.3	–	ww	1A	HRGS/UB/IB 20-12-GU5.3-51/60	48860VWFL	–	–	–
QR-CBC51/8° IRC	30	GU5.3	–	ww	1A	HRGS-30-12-GU5.3-50/8	–	MASTERLine ES 30W GU5.3 12V 8D	–	–
QR-CBC51/24° IRC	30	GU5.3	–	ww	1A	HRGS-30-12-GU5.3-50/24	–	MASTERLine ES 30W GU5.3 12V 24D	–	–
QR-CBC51/36° IRC	30	GU5.3	–	ww	1A	HRGS-30-12-GU5.3-50/36	–	MASTERLine ES 30W GU5.3 12V 36D	–	–
QR-CBC51/60° IRC	30	GU5.3	–	ww	1A	HRGS-30-12-GU5.3-50/60	–	MASTERLine ES 30W GU5.3 12V 60D	–	–
QR-CBC51/8° IRC	35	GU5.3	–	ww	1A	HRGS-35-12-GU5.3-50/8	–	MASTERLine ES 35W GU5.3 12V 8D	–	–
QR-CBC51/10° IRC	35	GU5.3	–	ww	1A	HRGS/UB/IB-35-12-GU5.3-51/10	48865SP	–	–	–
QR-CBC51/24° IRC	35	GU5.3	–	ww	1A	HRGS/UB/IB-35-12-GU5.3-51/24	48865FL	MASTERLine ES 35W GU5.3 12V 24D	–	–
QR-CBC51/36° IRC	35	GU5.3	–	ww	1A	HRGS/UB/IB-35-12-GU5.3-51/36	48865WFL	MASTERLine ES 35W GU5.3 12V 36D	–	–
QR-CBC51/60° IRC	35	GU5.3	–	ww	1A	HRGS/UB/IB-35-12-GU5.3-51/60	48865VWFL	MASTERLine ES 35W GU5.3 12V 60D	–	–
QR-CBC51/8° IRC	45	GU5.3	–	ww	1A	HRGS-45-12-GU5.3-50/8	–	MASTERLine ES 45W GU5.3 12V 8D	–	–
QR-CBC51/24° IRC	45	GU5.3	–	ww	1A	HRGS-45-12-GU5.3-50/24	–	MASTERLine ES 45W GU5.3 12V 24D	–	–
QR-CBC51/36° IRC	45	GU5.3	–	ww	1A	HRGS-45-12-GU5.3-50/36	–	MASTERLine ES 45W GU5.3 12V 36D	–	–
QR-CBC51/60° IRC	45	GU5.3	–	ww	1A	HRGS-45-12-GU5.3-50/60	–	MASTERLine ES 45W GU5.3 12V 60D	–	–
QR-CBC51/10° IRC	50	GU5.3	–	ww	1A	HRGS/UB/IB-50-12-GU5.3-51/10	48870SP	–	–	–
QR-CBC51/24° IRC	50	GU5.3	–	ww	1A	HRGS/UB/IB-50-12-GU5.3-51/24	48870FL	–	–	–
QR-CBC51/36° IRC	50	GU5.3	–	ww	1A	HRGS/UB/IB-50-12-GU5.3-51/36	48870WFL	–	–	–
QR-CBC51/60° IRC	50	GU5.3	–	ww	1A	HRGS/UB/IB-50-12-GU5.3-51/60	48870VWFL	–	–	–
High voltage halogen incandescent lamps										
QT32/m	60	E27	790	ww	1A	HSGST/F/UB-60-230-E27	64472 IM	HalogenA 13658 60W E27 230V T32 FR	–	–
QT32/m	75	E27	1050	ww	1A	HSGST/F/UB-75-230-E27	64474 IM	–	–	–
QT32/m	100	E27	1470	ww	1A	HSGST/F/UB-100-230-E27	64476 IM	HalogenA 13662 100W E27 230V T32 FR	DLX/T Satin 100W	–
QT32/m	150	E27	2400	ww	1A	HSGST/F/UB-150-230-E27	64478 IM	HalogenA 13946 150W E27 230V T32 FR	DLX/T Satin 150W	–
QT32/m	230	E27	4210	ww	1A	HSGST/F/UB-230-230-E27	64480 IM	–	–	–
QT-DE11/12	60	R7s	840	ww	1A	HDG-60-230-R7s-74.9	64688	Plusline Compact 60W R7s/18 230V	DE 230V 60W	–
QT-DE11/12	100	R7s	1600	ww	1A	HDG-100-230-R7s-74.9	64690	Plusline Compact 100W R7s/18 230V	DE 230V 100W	K14/Q100 T2.5/CL
QT-DE11/12 (L=74.9)	150	R7s	2500	ww	1A	HDG-150-230-R7s-74.9	64695	Plusline Compact 150W R7s/18 230V	DE 230V 150W	K12/Q150 T2.5/CL
QT-DE11/12 (L=114.2)	150	R7s	2600	ww	1A	HDG-150-230-R7s-114.2	64696	–	–	K28/Q150 T2.5/CL
QT-DE11/12 (L=114.2)	200	R7s	3500	ww	1A	HDG-200-230-R7s-114.2	64698	Plusline Small 200W R7s 230V	DE 230V 200W	K11/Q200 T2.5/CL
QT-DE11/12	300	R7s	5300	ww	1A	HDG-300-230-R7s-114.2	64701	Plusline Small 300W R7s 230V	DE 230V 300W	K9/Q300 T2.5/CL
QT-DE11/12	500	R7s	9500	ww	1A	HDG-500-230-R7s-114.2	64702	Plusline Small 500W R7s 230V	DE 230V 500W	K1/Q500 T2.5/CL
QT-DE11/12	750	R7s	16500	ww	1A	HDG-750-230-R7s-185.7	64560	Plusline Large 750W R7s 230V	–	K3/Q750 T3/CL
QT-DE11/12	1000	R7s	22000	ww	1A	HDG-1000-230-R7s-185.7	64740	Plusline Large 1000W R7s 230V	DE 230V 1000W	K10/1000 T3/CL
High voltage halogen incandescent lamps with reflector										
QPAR51/36°	20	GU10	–	ww	1A	HAGS-20-230-GU10-51/36	–	–	–	Q20MR16/230/FL
QPAR51/40°	20	GU10	–	ww	1A	HAGS-20-230-GU10-51/40	–	Twistline Alu 2000h 20W GU10 230V 40D	–	–
QPAR51/20°	35	GU10	–	ww	1A	HAGS-35-230-GU10-51/20	–	Twistline Alu 2000h 35W GU10 230V 20D	–	–
QPAR51/25°	35	GU10	–	ww	1A	HAGS-35-230-GU10-51/25	–	–	HI-SPOT ES 50 35W/FL25°	–
QPAR51/35°	35	GU10	–	ww	1A	HAGS/UB-35-230-GU10-51/35	64820 FL	–	–	Q35MR16/230/FL
QPAR51/40°	35	GU10	–	ww	1A	HAGS-35-230-GU10-51/40	–	Twistline Alu 2000h 35W GU10 230V 40D	–	–
QPAR51/20°	50	GU10	–	ww	1A	HAGS-50-230-GU10-51/20	–	Twistline Alu 2000h 50W GU10 230V 20D	–	–
QPAR51/25°	50	GU10	–	ww	1A	HAGS-50-230-GU10-51/25	–	Twistline Alu 3000h 50W GU10 230V 25D	–	–
QPAR51/35°	50	GU10	–	ww	1A	HAGS/UB-50-230-GU10-51/35	64824 FL	–	–	Q50MR16/230/25°
QPAR51/40°	50	GU10	–	ww	1A	HAGS-50-230-GU10-51/40	–	Twistline Alu 2000h 50W GU10 230V 40D	–	–
QPAR51/50°	50	GU10	–	ww	1A	HAGS-50-230-GU10-51/50	–	Twistline Alu 3000h 50W GU10 230V 50D	–	–
High voltage incandescent lamps										
IT	15	E14	110	ww	1A	IBC/F-15-230-E14-26	SPC. T26/57 FR 15 W 230 V E14	Deco 15W E14 230-240V T25 FR	–	15T25/CL/E14
IT	25	E14	190	ww	1A	IBC/F-25-230-E14-26	SPC. T26/57 FR 25 W 230 V E14	Deco 25W E14 230-240V T25 FR	–	25T25/CL/E14
A55/m	40	E27	415	ww	1A	IAA/F-40-230-E27-55	CLAS A FR 40	Standard 40W E27 230V A55 FR	GLS Long Life 40W 240V E27 Satin	40A1/FR/E27
A55/m	60	E27	710	ww	1A	IAA/F-60-230-E27-55	CLAS A FR 60	Standard 60W E27 230V A55 FR	GLS Long Life 60W 240V E27 Satin	60A1/FR/E27
A55/m	75	E27	935	ww	1A	IAA/F-75-230-E27-55	CLAS A FR 75	Standard 75W E27 230V A55 FR	GLS Long Life 75W 240V E27 Satin	75A1/FR/E27
A55/m	100	E27	1340	ww	1A	IAA/F-100-230-E27-55	CLAS A FR 100	Standard 100W E27 230V A55 FR	GLS 100W 240V E27 Pearl	100A1/FR/E27
A65/m	150	E27	2160	ww	1A	IAA/F-150-230-E27-65	CLAS A FR 150	Standard 150W E27 230V A65 FR	GLS 150W 240V E27 Pearl	150A1/FR/E27
A80/m	200	E27	3040	ww	1A	IAA/F-200-230-E27-80	CLAS A FR 200	Standard 200W E27 230V A80 FR	GLS 200W 240V E27 Pearl	200A1/FR/E27

Please note: subject to alteration. The list represents a selection from manufacturers' lamp ranges. Specifications for luminous flux, colour temperature and colour rendition as well as the ILCOS code mostly correspond to the first specified manufacturer's lamp designation within the row. It is the responsibility of the user to ascertain suitability of lamps for Siteco luminaires.

Lamps	ZVEI	Lamp rating in [Watt]	Power consumption in [Watt] with					
			nominal	ECG	ECG DALI	ECG dimmable (1...10V)	LLCG	CCG
2	T16	8	18	-	-	-	-	-
1	T16	14	16	16	16	-	-	-
2	T16	14	31-32	31	31-36	-	-	-
3	T16	14	47-48	46	46-64	-	-	-
4	T16	14	64-65	61	61	-	-	-
1	T16	21	25	24	24	-	-	-
2	T16	21	47	45	45-50	-	-	-
1	T16	28	31-32	31	31	-	-	-
2	T16	28	63-64	61-63	61-64	-	-	-
4	T16	28	126	-	-	-	-	-
1	T16	35	39	39	38-39	-	-	-
2	T16	35	75-79	74-78	74-77	-	-	-
4	T16	35	158	-	-	-	-	-
1	T16	24	27	26	26	-	-	-
2	T16	24	51-54	50-55	50-55	-	-	-
3	T16	24	78	74	74-82	-	-	-
4	T16	24	102	98	98	-	-	-
1	T16	39	43-44	42	42-44	-	-	-
2	T16	39	88	82	82	-	-	-
1	T16	54	59-62	59-62	59-61	-	-	-
2	T16	54	118-119	115-118	115-118	-	-	-
3	T16	54	179	-	-	-	-	-
4	T16	54	236	-	-	-	-	-
1	T16	49	43-55	54-55	54-55	-	-	-
2	T16	49	110	102-111	102-111	-	-	-
3	T16	49	164	-	-	-	-	-
4	T16	49	220	-	-	-	-	-
1	T16	80	86-91	89	86-88	-	-	-
2	T16	80	176	169-178	169-176	-	-	-
3	T16	80	262	-	-	-	-	-
4	T16	80	352	-	-	-	-	-
1	T26	18	19	18	18-19	24-30	-	-
2	T26	18	36	37	36-37	46	-	-
3	T26	18	55	54	54	70-72	-	-
4	T26	18	72	70	70	89	-	-
1	T26	36	34	36	36	42-46	-	-
2	T26	36	70	69	69-71	84-96	-	-
1	T26	38	35	-	-	-	-	-
1	T26	58	48-53	56-62	56	67-71	-	-
2	T26	58	95-106	108-119	108-111	134-142	-	-
4	T26	58	220	-	222	-	-	-
1	TC-S	9	-	-	-	13	-	-
2	TC-S	9	-	-	-	26	-	-
2	TC-S	11	-	-	-	28	-	-
2	TC-SEL	11	25	-	-	-	-	-
1	TC-D	13	-	-	-	17	-	-
2	TC-D	13	-	-	-	34	-	-
1	TC-D	18	-	-	-	24	-	-
2	TC-D	18	-	-	-	48	-	-
1	TC-D	26	-	-	-	34	-	-
2	TC-D	26	-	-	-	68	-	-
1	TC-DEL	13	16	-	-	-	-	-
2	TC-DEL	13	25	-	-	-	-	-
1	TC-DEL	18	20	20	20	-	-	-
2	TC-DEL	18	36	-	-	-	-	-
1	TC-DEL	26	28	28	28	-	-	-
2	TC-DEL	26	52	-	53	-	-	-
1	TC-T	26	-	-	-	34	-	-
1	TC-TEL	13	16	-	-	-	-	-
2	TC-TEL	13	25	-	-	-	-	-
1	TC-TEL	18	20	20	20	-	-	-
1	TC-TEL	26	27-28	28	28	-	-	-
2	TC-TEL	26	52-54	53	53-56	-	-	-
3	TC-TEL	26	80	-	-	-	-	-
1	TC-TEL	32	35	36	35-36	-	-	-
2	TC-TEL	32	66-70	72	72	-	-	-
3	TC-TEL	32	100	-	-	-	-	-
1	TC-TEL	42	46	46	46	-	-	-
2	TC-TEL	42	90-93	91	91-93	-	-	-
3	TC-TEL	42	138	-	-	-	-	-
1	TC-TELI	18	20	20	20	-	-	-
2	TC-TELI	18	36	37	37	-	-	-
1	TC-TELI	26	27-28	28	28	-	-	-
2	TC-TELI	26	52-54	53	53-56	-	-	-
1	TC-TELI	32	35	36	35	-	-	-
2	TC-TELI	32	66-70	72	72	-	-	-
1	TC-TELI	42	46	46	46	-	-	-
2	TC-TELI	42	90-93	91	91-93	-	-	-
1	TC-TELI	57	62	-	-	-	-	-
1	TC-TELI	60	63	-	-	-	-	-
1	TC-TELI	85	92	-	-	-	-	-
1	TC-TELI	120	133	-	-	-	-	-
1	TC-L	18	20	18	18	30	-	-
2	TC-L	18	38	37	37	46	-	-
2	TC-L	24	52-54	50	50	60-70	-	-
1	TC-L	36	39	36	36	-	-	-
1	TC-L	40	45	42	42	-	-	-
1	TC-L	55	61	59	56-59	-	-	-
2	TC-L	55	121	115	111-115	-	-	-
3	TC-L	55	182	-	167	-	-	-
4	TC-L	55	242	-	222	-	-	-
2	TC-L	80	176	169	169	-	-	-
3	TC-L	80	183	-	-	-	-	-
4	TC-L	80	352	-	-	-	-	-
1	T16-R	40	44-45	45	45	-	-	-
1	T16-R	55	60	60	60-62	-	-	-

Lamps	ZVEI	Lamp rating in [Watt]	Power consumption in [Watt] with						
			nominal	ECG	ECG DALI	ECG dimmable (1...10V)	LLCG	CCG	Transformer
1	TC-DD	16	-	-	-	-	24	-	-
1	HIE	70	-	-	-	-	-	96	-
1	HIE	100	-	-	-	-	-	115	-
1	HIE	150	-	-	-	-	-	170	-
1	HIE	250	-	-	-	-	-	275	-
1	HIE	400	-	-	-	-	-	460-470	-
1	HIE	1000	-	-	-	-	-	1065	-
1	HIE-CE	70	-	-	-	-	-	85	-
1	HIE-CE	150	-	-	-	-	-	167	-
1	HIE-CE	250	-	-	-	-	-	289	-
1	HIE-CE	400	-	-	-	-	-	448	-
1	HIT-TC-CE	20	25	-	-	-	-	-	-
1	HIT-TC-CE	35	43	-	-	-	-	-	-
1	HIT-TC-CE	70	80	-	-	-	-	88	-
1	HIT-CE	35	43-48	-	-	-	-	50	-
1	HIT-CE	70	80-88	-	-	-	-	80-92	-
1	HIT-CE	100	-	-	-	-	-	114	-
1	HIT-CE	150	163	-	-	-	163	167-187	-
1	HIT-CE	250	-	-	-	-	-	270	-
1	HIT	70	-	-	-	-	-	91	-
1	HIT	150	-	-	-	-	-	170	-
1	HIT	250	-	-	-	-	-	275	-
2	HIT	250	-	-	-	-	-	550	-
1	HIT	400	-	-	-	-	-	460-470	-
2	HIT	400	-	-	-	-	-	920-940	-
1	HIT	1000	-	-	-	-	-	1065	-
1	HIT-DE	70	-	-	-	-	-	94-95	-
1	HIT-DE	150	-	-	-	-	-	170	-
1	HIT-DE	250	-	-	-	-	-	275	-
1	HIT-DE	400	-	-	-	-	-	440	-
1	HIT-DE	1000	-	-	-	-	-	1065	-
2	HIT-DE	1000	-	-	-	-	-	2130	-
3	HIT-DE	1000	-	-	-	-	-	3195	-
1	HIT-DE	2000	-	-	-	-	-	2030	-
1	HIT-DE Longarc	2000	-	-	-	-	-	2030	-
1	HME	50	-	-	-	-	-	59	-
2	HME	50	-	-	-	-	-	118	-
1	HME	80	-	-	-	-	-	89	-
2	HME	80	-	-	-	-	-	178	-
6	HME	80	-	-	-	-	-	534	-
1	HME	125	-	-	-	-	-	137	-
2	HME	125	-	-	-	-	-	274	-
6	HME	125	-	-	-	-	-	822	-
1	HME	250	-	-	-	-	-	265	-
4	HME	250	-	-	-	-	-	1064	-
1	HME	400	-	-	-	-	-	425	-
1	HME	1000	-	-	-	-	-	1045	-
1	HSE	50	-	-	-	-	-	62	-
2	HSE	50	-	-	-	-	-	124	-
6	HSE	50	-	-	-	-	-	372	-
1	HSE	70	-	-	-	-	-	83	-
2	HSE	70	-	-	-	-	-	166	-
6	HSE	70	-	-	-	-	-	498	-
1	HSE	100	-	-	-	-	-	115	-
2	HSE	100	-	-	-	-	-	230	-
1	HSE	150	-	-	-	-	-	170-176	-
2	HSE	150	-	-	-	-	-	340	-
4	HSE	150	-	-	-	-	-	704	-
6	HSE	150	-	-	-	-	-	1056	-
1	HSE	250	-	-	-	-	-	275-285	-
6	HSE	250	-	-	-	-	-	1710	-
1	HSE	400	-	-	-	-	-	440	-
1	HSE	1000	-	-	-	-	-	1075	-
1	HST	50	-	-	-	-	-	66	-
2	HST	50	-	-	-	-	-	124	-
1	HST	70	-	-	-	-	-	83	-
2	HST	70	-	-	-	-	-	166	-
1	HST	100	-	-	-	-	-	115	-
2	HST	100	-	-	-	-	-	230	-
1	HST	150	-	-	-	-	-	170-176	-
2	HST	150	-	-	-	-	-	340-352	-
6	HST	150	-	-	-	-	-	1056	-
1	HST	250	-	-	-	-	-	285	-
2	HST	250	-	-	-	-	-	570	-
6	HST	250	-	-	-	-	-	1710	-
1	HST	400	-	-	-	-	-	440	-
2	HST	400	-	-	-	-	-	880	-
6	HST	400	-	-	-	-	-	2700	-
1	HST	1000	-	-	-	-	-	1075	-
1	HST-DE	70	83	-	-	-	-	83	-
1	HST-DE	150	-	-	-	-	-	170	-
1	HST-DE	250	-	-	-	-	-	275-285	-
1	HST-DE	400	-	-	-	-	-	440	-
1	HST-CRI	35	-	-	-	-	-	42	-
1	HST-CRI	50	69	-	-	-	-	69	-
1	HST-CRI	100	110	-	-	-	-	-	-
1	QT12	75	-	-	-	-	-	-	79
1	QT12	90	-	-	-	-	-	-	96

Please note: subject to alteration. The table is an indication for median power consumption of lamps in combination with ballasts. In most cases, specifications from ballast manufacturers have been implemented. Power consumption is among other factors dependent upon the interaction of lamps and ballasts as well as operating temperatures of these components. The power consumption of the installation can therefore deviate from specified values due to manufacturing tolerances of lamps and ballasts and also temperatures on-site. The lamp types A55, A65, A80, QT32, QT-DE11/12, QPAR51 and TCR-TSE flat are operated without ballasts. Power consumption in these cases therefore corresponds to lamp wattage.

In General

At the end of 2002 the Ordinance on Maximum Energy Consumption (EnVHV) came into effect. This is the implementation of the 2000/55/EG European Directive, which forms the basis for the designation of ballasts with energy classes.

In the past, series power factor correction was the norm due to power authorities. This has changed as a result of technical connection conditions, Edition 2000 (TAB2000). Apart from a few exceptions, parallel power factor correction is now standard.

Energy Classification

Electrical consumers are divided into 7 energy classes (A1, A2, A3, B1, B2, C, D), whereby Class A1 represents the greatest energy efficiency.

With luminaires, energy efficiency is specified as a complete system of light source, control gear and power factor correction. As such, luminaire switching for fluorescent lamps is divided into the following:

A1:	... with ECG dimming and daylight-similar control
A2, A3:	... with ECG
B1, B2:	... with LLCG (not power factor corrected)
C:	... with CCG (not permissible since 11/2005)
D:	... with poor CCG (not permissible since 11/2003)

With series power factor correction (capacitive switching), energy classification fundamentally leads to a lower classification compared to inductive switching (without power factor correction). This is the reason why inductive ballasts of classes B1 and B2 have been integrated into energy class C or even in specific cases into energy class D. The difference in power consumption may make up to 15 % here.

Power Factor Correction

Luminaires with electronic control gear represent lighting solutions with greatest energy savings and cost-efficiency.

Additional power factor correction is not necessary. For luminaires with inductive control gear we recommend parallel power factor correction as the most energy-efficient solution (if no limitations are made by power authorities and if no central correction facility is available).

Power Factor Correction in Delivery State

- Siteco luminaires for fluorescent lamps are available either with ECG (additional correction not necessary), with parallel power factor correction ex-works (with installed capacitor) or inductive (not prepared for correction).
- Downlights for compact fluorescent lamps are factory-set for parallel power factor correction (please note specifications in product descriptions).
- Luminaires for fluorescent lamps for series correction are available as customer-specific variations.
- Luminaires for high pressure discharge lamps are with parallel power factor correction ex-works (with installed capacitor).

Subsequent On-Site Correction

For retroactive conversion of luminaires to parallel p. f. correction on-site, capacitors (equipped with plug-in terminals) are necessary. Capacitance of capacitors is dependent upon the complete lamp rating of each luminaire (selection from list opposite).

Retroactive correction must only be carried out by a qualified electrician. Installation instructions must be followed.

- Retroactive correction is only permissible for insulation class I indoor and damp-proof luminaires for tubular and compact fluorescent lamps.
- Insulation class II luminaires and luminaires for high pressure discharge lamps must not be retroactively corrected.
- With luminaires featuring electronic control gear, no correction is necessary.

Capacitors include plug-in terminal for power factor correction.

For Mounting (W)	PF Correction Capacitor Amount/Capacity	Amount/Order No.
------------------	---	------------------

Compact Fluorescent Lamps

TC-S

1 x TC-S 5 / 7 / 9 / 11W	1 x 2uF	1 x 5LY5020
2 x TC-S 5 / 7 / 9 / 11W	1 x 4uF	1 x 5LY5018

TC-D

1 x TC-D 10 / 13W	1 x 2uF	1 x 5LY5020
1 x TC-D 26W	1 x 4uF	1 x 5LY5018
2 x TC-D 10 / 13W	1 x 4uF	1 x 5LY5018
2 x TC-D 18W	1 x 5uF	1 x 5LY5013
2 x TC-D 26W	1 x 8uF	1 x 5LY5015

TC-T

1 x TC-D 10 / 13W	1 x 2uF	1 x 5LY5020
1 x TC-D 26W	1 x 4uF	1 x 5LY5018
2 x TC-D 10 / 13W	1 x 4uF	1 x 5LY5018
2 x TC-D 18W	1 x 5uF	1 x 5LY5013
2 x TC-D 26W	1 x 8uF	1 x 5LY5015

TC-L

1 x TC-L 18W	1 x 4,5uF	1 x 5LY5016
1 x TC-L 24W	1 x 4uF	1 x 5LY5018
1 x TC-L 36W	1 x 4,5uF	1 x 5LY5016
2 x TC-L 18W	1 x 4,5uF ¹⁾	1 x 5LY5016
2 x TC-L 24W	1 x 8uF	1 x 5LY5015
2 x TC-L 36W	1 x 9uF	1 x 5LY5003
3 x TC-L 18W	1 x 9uF ¹⁾	1 x 5LY5003
3 x TC-L 24W	1 x 10uF	1 x 5LY5014
3 x TC-L 36W	1 x 13,5uF	1 x 5LY5005

Tubular Fluorescent Lamps

T26

1 x 18W	1 x 4,5uF	1 x 5LY5016
1 x 36W	1 x 4,5uF	1 x 5LY5016
1 x 38W	1 x 4,5uF	1 x 5LY5016
1 x 58W	1 x 7uF	1 x 5LY5002
2 x 18W	1 x 4,5uF ¹⁾	1 x 5LY5016
2 x 36W	1 x 9uF	1 x 5LY5003
2 x 38W	1 x 9uF	1 x 5LY5003
2 x 58W	1 x 13,5uF	1 x 5LY5005
3 x 18W	1 x 9uF ¹⁾	1 x 5LY5003
3 x 36W	1 x 13,5uF	1 x 5LY5005
3 x 58W	1 x 20uF	1 x 5LY5008
4 x 18W	1 x 9uF ¹⁾	1 x 5LY5003
4 x 36W	1 x 18uF	1 x 5LY5007
4 x 58W	2 x 13,5uF	2 x 5LY5005
	or	or
	1 x 25uF	1 x 5LY5028

1) Only when two lamps are in tandem connection (2 lamps 18W on one control gear unit 36W).

■ For each capacitor, a terminal is required, as long as the luminaire is not prepared for "PF Correction" (see luminaire description).

Luminaires with integral emergency inverter

Equipping and Functionality:

Luminaires wired ready for connection, with 4-pole mains connection (3-pole for 'normal mains' with switched phase* + single pole for additional unswitched phase* for integral emergency inverter) | with ECG for normal operation and with integral emergency inverter* for emergency operation (control device, battery for 1 hour or 3 hour operation and with LED for optical self-test functioning control of battery)

$$U_N = 220...240V/AC\ 50...60Hz$$

* The switched phase (mains supply) and the unswitched phase must have the same phase angle | the emergency battery is charged via the non-switched phase and the luminaire is informed of the operational condition (mains or emergency):

- non-switched phase in operation: ---> normal operation (luminaire operation via mains, normal on/off switching)
- non-switched phase missing: ---> emergency operation with reduced luminous flux (operation with battery) | luminaire is switched on, even when luminaire was switched off with mains operation

LED signals:

- green LED: battery connected and charged
- green blinking LED: battery being charged
- red blinking LED: battery not connected or defect
- yellow blinking LED: automatic discharging/charging of battery

Emergency operation with reduced lumen output:

reduced lumen output (see table)

with 2-lamp luminaires: operation with one lamp

luminaires with ECG DALI or ECG dimming (1...10V):

lumen output as given, independent of dimming status

Permissible ambient temperature for luminaire use with integral emergency inverter:

0°C to 25°C

Schematic Circuit Diagram:

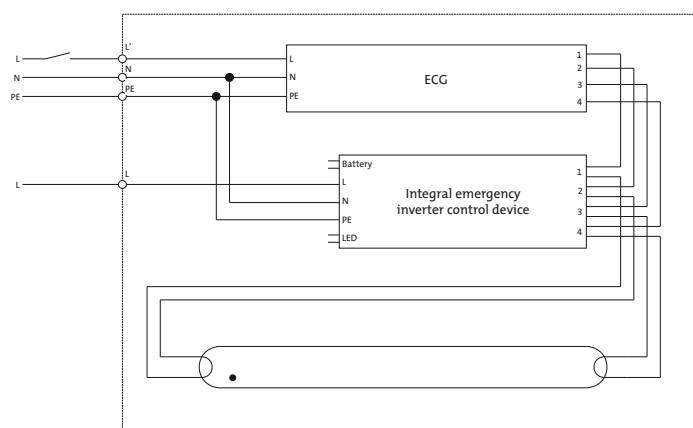

Integral Emergency Inverter for On-Site Installation

Short Description

Integral emergency inverter for retroactive, on-site installation, consisting of control device, NiMh or NiCd battery for 1h or 3h operation and LED for optical self-testing. Suitable for emergency operation of fluorescent lamps (T16, T26 or TC lamps without integral glow starter), for single-lamp and multi-lamp ECG, ECG dimming or LLCG.

Scope of Delivery

Housing of control device of sheet steel (for screw fixing). Gas-tight and maintenance-friendly battery (with cable retainers and self-adhesive mounting elements, LED (with LED clip) and self-adhesive colour spots (for colour-identification of luminaire and lamp).

Electrics

All components wired ready for connection: control device with screwless terminals, max. 1.5mm², battery and LED with pre-assembled connection cable

$$U_N = 220...240V/50...60Hz; I (230V) = 4...40mA; \lambda = 0.8$$

For luminaires with integral emergency inverter, a 4-pole mains connection is required (3-pole for 'normal mains' with switched phase* + 1-pole for additional unswitched phase* for integral emergency inverter).

Functionality and Further Explanation

(see description 'Luminaires with Integral Emergency Inverter')

Emergency operation with reduced luminous flux (see table)

with twin- and multi-lamp luminaires: operation with one lamp (independent of ballast)

luminaires with ECG DALI or ECG dimming (1...10V):

lumen output as given, independent of dimming status

Recommended applications

For installations according to VDE0108 or EN 60598-2-22

Integral emergency inverter for on-site installation



Integral Emergency Inverter

Integral emergency inverter for on-site installation in luminaires | for 1 hour or 3 hour operation | components: control unit, battery (capacitance according to required operating life and selected lamp rating) and LED (for optical self-testing of battery) | suitable for emergency operation of fluorescent lamps (T16, T26 or TC lamps without integral glow starter) | for installation in luminaires with single or multi-lamp ECG, ECG dimming or LLCG

Protection rating: IP20

Insulation class: I

Permissible ambient temperature:

- for integral emergency inverter: 0°C to 45°C

- for luminaire with integral emergency inverter:
0°C to 25°C

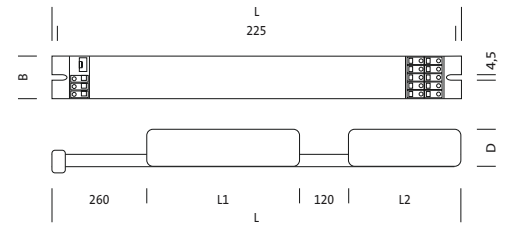

Bestückung	L (mm)	B (mm)	H (mm)	L1 (mm)	L2 (mm)	D (mm)	Order No.
Integral Emergency Inverter							
Inverter	235	30	21				5LY11103R
+ NiMh battery 3,0 Ah	740			215	145	19	
Inverter	235	30	21				5LY11104R
+ NiCd battery 4,5 Ah	680			190	120	33	
Inverter	235	30	21				5LY11105R
+ NiCd battery 7,0 Ah	830			270	260	33	

- Inverter dimensions: L x B x H; mounting distance l = 225 mm
 Dimensions battery 1: L1 x D; connection cable to inverter: l1 = 260 mm
 Dimensions battery 2: L2 x D; connection cable between batteries: l2 = 120 mm

Luminous flux with emergency operation (% of nominal luminous flux)

Lamp	T26				T16					T16					
	18W	36W	38W	58W	8W	11W	14W	21W	28W	35W	24W	39W	49W	54W	80W
Lumin. flux	18%	13%	13%	10%	31%	28%	26%	22%	21%	15%	19%	14%	9%	14%	9%
required battery capacitance dependent upon required operational life and lamp															
1h (Ah)	3,0	3,0	3,0	3,0	3,0	3,0	3,0	3,0	3,0	3,0	3,0	3,0	3,0	3,0	3,0
3h (Ah)	4,5	4,5	7,0	7,0	4,5	4,5	4,5	7,0	7,0	7,0	4,5	7,0	7,0	7,0	7,0

Lamp	TC-L						TC-DEL			TC-TEL				TC-SEL		
	18W	24W	36W	40W	55W	80W	13W	18W	26W	18W	26W	32W	42W	7W	9W	11W
Lumin. flux	17%	17%	16%	14%	12%	8%	27%	26%	22%	26%	18%	19%	16%	31%	30%	28%
required battery capacitance dependent upon required operational life and lamp																
1h (Ah)	3,0	3,0	3,0	3,0	3,0	3,0	3,0	3,0	3,0	3,0	3,0	3,0	3,0	3,0	3,0	3,0
3h (Ah)	4,5	4,5	4,5	7,0	7,0	7,0	4,5	4,5	4,5	4,5	4,5	7,0	7,0	4,5	4,5	4,5

- with twin- and multi-lamp luminaires: operation with one lamp

Quality of Light

For the assessment of a lighting situation, a whole range of criteria can be considered. Quantifiable, optical magnitudes play as important a role as factors that cannot be numerically described and that are strongly influenced from subjective perceptions. The so-called 'lighting design quality attributes' that are often referenced to in practise have become a centre of interest, and are often discussed in detail in trade magazines.

Lighting Level

Eyestrain and accurate viewing depend to a very large extent upon the lighting level. The lighting level is measured in terms of the illuminance (in Lux/lx). The higher the lighting level, the higher the viewing performance, i.e. the accuracy and promptness with which the eye can gather visual information.

The lighting level in natural conditions, depending upon weather, time and location lies between 5 000 and 100,000 Lux. Indoors, such high levels are impractical because of the required artificial light levels. A minimum value of 500 lux now exists for typical viewing tasks such as office work. New studies however confirm that a higher lighting level has a positive effect upon the general well-being of people and their work performance.

The relevant norms contain minimum lighting levels for varying indoor and outdoor situations.

Lighting Direction and Shadow

The interplay of light and shadow is decisive for the spacial perception of rooms. Light direction and shadowing allow objects to appear three-dimensional and also give them depth. For the faultless recognition of objects, surfaces and structures, a suitable lighting installation is required. A bright space with solely diffuse light without shadowing has the effect of being monotonous. Lack of orientation and the inadequate recognition of objects and distances leads to discomfort. In contrast, a correct ratio of diffuse light (e.g. with indirect distribution) to directional light results in a pleasant shadow effect. Directional light models structures and creates dramaturgy.

Typical instruments for directional light are narrow beam spots or downlights that are equipped with spot sources and bundled reflector systems. These luminaires are adjustable for situations where a spacial setting of the light output is required (i.e. rotational, pivotable, focussable).

Glare

Basically, two forms of glare can be distinguished. Firstly, glare resulting from physiological conditions and secondly a psychological glare. Physiological glare designates the situation in which too high or too low a level of contrast occurs, leading to an acute and measurable reduction of visual performance.

Psychological glare signifies when a lighting situation either short-term or long-term has a disturbing influence. This is statistically determined (by surveys). Both forms of glare can be caused by the light source itself (direct glare) or through reflections of light sources on surfaces (reflected glare). This leads to discomfort and impairs performance and concentration ability. On the basis of occupational safety and ergonomics, glare should therefore be avoided.

Brightness is measured in terms of luminance (candela/square metre, cd/m²). The luminance values are evaluated with the light emission aperture of a luminaire that lies within the field of vision or the direction of viewing.

The degree of (psychological) direct glare from luminaires as part of a lighting system in indoor spaces is measured today with the CIE Unified Glare Rating System (UGR). Here the absolute luminance value of the light emission aperture of the luminaire is not alone decisive, but also the luminance ratio of room surfaces, the alignment of the luminaire in the field of vision and the room size.

With reflected glare, the glare occurs indirectly. The light of the luminaire is mirrored with a medium (for example a magazine or computer monitor) into the field of view of the observer. This can be reduced or completely avoided if the brightness of the luminaire is reduced or the geometrical proportions of the luminaire to the surface and the eye are changed, or when the surface is matt, thus avoiding glare.

Flickering and Stroboscopic Effects

With luminaires with discharge lamps, flickering and stroboscopic effects can occur as a result of AC current. Flickering causes visual impairments, tiredness and headaches.

Objects that move quickly (for example rotating machine parts) can under adverse lighting conditions be perceived as stationary in cases where the chronological change in luminous flux runs simultaneously to the actual movement itself (stroboscopic effect). This can in certain circumstances be exceedingly dangerous.

In order to eliminate flicker and stroboscopic effects it is recommended to operate lamps with an electronic ballast. The use of electronic ballasts saves energy in comparison to conventional ballasts, extends the life cycle of the lamps and provides a high level of convenience when controlling and maintaining the lighting system.

Colour Rendering and Light Colour

In natural daylight the surfaces of objects appear in their true colours. This lighting situation forms the benchmark for colour perception with artificial light. The colour rendering characteristics of an artificial light source are expressed in terms of the colour rendering index (CRI). This measures the degree to which objects illuminated by the source conform with the same objects illuminated by a reference illuminant. Incandescent lamps, due to their continuous colour spectrum, have the best colour rendition. Discharge lamps have all colour rendition grades. It is currently being debated whether to amend the index, because LEDs are adversely evaluated.

The area of use determines the colour rendering properties of a light source. Where colour authenticity is important, eg. for inspection tasks, retail spaces for foodstuffs, textiles, print media, the automotive industry and in museums, light sources with good colour rendition are used. With the illumination of products in retail areas (especially fresh produce such as meat, fruit, vegetables, etc.), lamps and luminaire systems are implemented that emphasise the red spectral components of fresh goods and give these an appetising appearance.

In the area of all-purpose lighting for indoor spaces, fluorescent lamps, metal halide lamps and tungsten halogen lamps are generally used. Incandescent lamps usually have a warm white colour temperature (2700 – 3000 Kelvin), but with fluorescent lamps and metal halide lamps there is a selection of various white tones:

Warm white light has a higher red component. This gives the room a somewhat warmer appearance.

Colour temperature to 3300K.

Neutral white

Colour temperature 3300 – 5300K.

Daylight white light has a higher blue component. This makes the room cooler.

Colour temperature above 5300K.

At the present time, fluorescent lamps with colour temperatures of 8000K and greater are being introduced. The very high blue component in the spectrum of these lamps is intended to influence the receptors in the eye that regulate the hormone Melatonin, controlling the Circadian rhythm (day/night rhythm) of the body. It is hoped to achieve a similarly inspiring/awaking effect as with a blue sky on a sunny day.

Coloured Light

With coloured light, the colour perception of surfaces can be influenced. This can be deployed for orientation purposes, for signalling or for reasons of effect. The random creation of colours with RGB colour mixing is often to be found with contemporary lighting designs. Here the red, green and blue light components are layered on top of each other with the help of a lighting control system. Coloured fluorescent lamps or LED's are used here as light sources.

Light distribution and Light Characteristics

The distribution of deployed luminaires influences to a great extent the effect of illuminated spaces or objects.

Indoor Lighting

Direct light distribution is characterised by light that is radiated directly into the room or directly onto the working surface. In terms of lighting levels, direct distribution offers the highest efficiency. Depending upon the optical system of the luminaire, a direct viewing of the lamp and a corresponding glare effect should be taken into account.

With the deployment of suitable optical components such as diffusers (opalcent covers), refractors (prismatic enclosures), ELDAICON® technology and secondary systems, direct distribution luminaires can be designed with glare-free characteristics. Louvre optics ensure an absence of glare above a specific beam angle area.

With secondary luminaire systems, the light from the lamp is initially reflected from a primary reflector to a secondary reflector that are both enclosed in the luminaire, and from there it is directed into the room. The lamp cannot be seen. Secondary reflector systems also use secondary light distribution, however the light point resolution reflector and the projector are spacially separated from each other.

With indirect distribution, the light output from a luminaire is radiated into the room via a reflecting surface such as a wall or ceiling. A bright, friendly room appearance is created with glare-free illumination. However a purely indirect illumination creates a diffuse light atmosphere with a low level of shadows that may become monotonous and tiring.

Composite distribution characteristics, i.e. direct-indirect or indirect-direct distribution combine the advantages of both approaches and are frequently used for indoor lighting.

With reference to the beam angle, diffuse, wide, medium and narrow distribution characteristics are deployed. For a highest possible uniformity of surface illumination, diffuse, wide or medium distribution luminaires are predominantly used, whereas for accenting and the lighting of higher spaces narrow distribution is used.

Narrow beam characteristics are usually created with spot sources such as tungsten halogen lamps, metal-halide lamps and LEDs. Wide, medium and diffuse distribution can be created with the complete spectrum of lamps.

Outdoor Lighting

Outdoor lighting usually consists of street lighting, surface lighting, spotlighting and guidance lighting. Luminaires are mostly used with symmetrical or asymmetrical wide distribution. They are normally equipped with high pressure discharge lamps.

In the area of streetlighting a very low level of light spill outside of the target surfaces is vital. Firstly in order to keep light disturbances as low as possible for residents and secondly in order to reduce the attraction of insects and to avoid illuminating the night sky, and also to be able to implement the energy used as efficiently as possible. For this reason, light characteristics are preferred whereby light is exclusively emitted to the lower hemisphere and is targeted to the surfaces to be illuminated.

For specialised uses, for example the spotlighting of objects or the lighting of stadiums, projectors with narrow beam spreads are used. The same is true for the projectors of a secondary reflector system.

Standards, Directives and Lighting Information

With the calculation of lighting installations the lighting designer is recommended to abide by technological directives (e.g. DIN or EN standards) and legal stipulations (e.g. workplace guidelines, computer screen directives, professional association regulations), and he can also make use of explanatory information made available by professional associations, publications and lighting profession associations. For particular environments (e.g. rail marshalling yards), requirements may be made that exceed normal standards. As such, all rules and directives applicable for a lighting installation must be used and the highest demands specified must be fulfilled.

Relevant Standards:

DIN 5035	Lighting with Artificial Light Section 3: Lighting for Health Care Section 6: Measurement and Evaluation Section 7: Lighting of Rooms with DSE Workstations Section 8: Workstation Luminaires Requirements, Recommendations and Inspection
DIN 5039	Light, Lamps, Luminaires – Concepts and Classification
DIN 5040	Luminaires for Lighting Uses; Section 1: Optical Characteristics and Classification Section 2: Indoor Luminaires, Concepts and Classification Section 3: Outdoor Luminaires, Concepts and Classification Section 4: Projectors; Concepts and Optical Evaluation Parameters
DIN 5044-1	Stationary Traffic Lighting; lighting of roads for motor vehicle traffic; general quality attributes and guidelines
DIN EN 12665	Light and Lighting Basic concepts and criteria for specification of requirements for lighting
DIN EN 12464	Light and Lighting – Illumination of Workplaces Section 1: Indoor Workplaces Section 2: Outdoor Workplaces
DIN EN 13201	Road Lighting Section 1: Selection of Lighting Classifications Section 2: Quality Criteria Section 3: Calculation of Quality Attributes Section 4: Methods for Measurement of Quality Criteria for Streetlighting Installations
DIN EN 13032	Light and Lighting – Measurement and Presentation of Photometric Data for Lamps and Luminaires
DIN V 18599	Energy Evaluation of Buildings – Calculation of effective, end and primary energy requirements for heating, cooling, ventilation, drinking water and lighting Section 1: General evaluation process, concepts, zoning and evaluation of energy carriers Section 4: Effective and End Energy Requirements for Luminaires

DIN EN ISO 9241	Ergonomic Requirements for Office Activities with DSE screens Section 7: Requirements for Visual Presentation with Regard to Reflections
DIN EN 1838	Applied Lighting Technology – Emergency Lighting
CIE S 015:2005	2005 Lighting of Outdoor Work Places

Relevant Regulations:

Workplace Guidelines (ASR)

ASR 7/3	Artificial Lighting
ASR 7/4	Security Lighting
ASR 41/3	Artificial Lighting for Workplaces and Outdoor Traffic Routes

DSE Workstation Work Provision (BildscharbV)

Assembly Points Provision (country-specific)

Federal Immission Protection Law

BGR 131	Natural and Artificial Lighting of Workplaces; Section 1: Practical Aid for Business Section 2: Guidelines for Planning and Operation of Lighting
BGR 216	Optical Emergency Signal Systems (including security lighting)
D954.9103	Electrical Energy Facilities; lighting installations near to tracks and/or security relevant areas
D954.9103/LAWL*	Luminaire selection lists
D954.9103/MB1	Data sheet 1: luminaire clearance for German Railways

Helpful information:

BGI 650	DSE and Office Workstations - Design Guidelines
BGI 856	Office Lighting; aids for the planning of lighting installations for rooms with DSE and office workstations
LiTG Publication	The UGR process for evaluation of direct glare for artificial lighting of indoor areas
CIE 97-1992	Maintenance of indoor electric lighting systems
CIE 140-2000	Road lighting calculations
D81304	Designing Railway Stations for People; Planning Handbook for Equipping of Technical Buildings
ZVEI publication:	Guidelines for DIN EN 12464-1



Siteco's Technology and Design Centre offers scope for technology, know-how, dialogue and inspiration – the experience of light and transferal of knowledge under one roof. Let yourself be inspired by our lighting forum. Just speak to your sales representative. We can organise your personal training programme selected from our wide spectrum of training components, and can also organise the entire planning from arrival until departure.

Basics

- Perception of light: fundamentals of light perception
- Space, light, colour: basics of lighting technology
- Space, form and light: suggestions for creative lighting design
- Light and people: light as a biological factor

Indoor Lighting

- Trends and research in the area of office lighting
- Introduction to lighting planning for offices
- Planning criteria and planning tools for office lighting
- Realisation of practical lighting concepts
- Introduction to lighting planning for industrial facilities
- Introduction to lighting planning for retail areas
- Design and all-purpose lighting with downlights
- ELDAICON®: instruments for modern office lighting
- Siteco Mirrortec®: introduction to lighting with secondary reflector systems
- The new DIN: explanations of standards and their consequences for lighting design
- Energy saving with use of daylight
- Building Energy Passport: consequences and chances
- Introduction to lighting management

Outdoor Lighting

- Light for public spaces
- Seeing and being seen; quality criteria for outdoor lighting
- Fundamentals of streetlighting
- Light sources for outdoor lighting
- Obligatory lighting for public roads
- Standards for outdoor lighting
- Electrical safety for public lighting
- Outdoor lighting trends
- Overview of outdoor lighting equipment streetlighting, architectural lighting and lighting for sports
- Design of outdoor lighting installations
- Introduction to lighting planning for tunnels
- Outdoor lighting in use
- Innovative reflector technologies for outdoor lighting
- Lighting of roundabouts
- Lighting of pedestrian crossings
- Energy-saving switching for outdoor lighting
- Lighting management for outdoor lighting
- Simulation of road lighting with the light demonstration road
- Lighting effects of decorative outdoor lighting
- Refurbishment of lighting installations
- Avoidance of light immission
- Light and environmental protection

Order No.	Page	Order No.	Page	Order No.	Page	Order No.	Page
5AA16270B	9.16	5LA91211LA308	9.33	5LF28762F	7.9	5LF51B62JW	2.89
5AA16270B	9.16	5LA96011FA300	9.34	5LF28762X	7.9	5LF51B62PW	2.89
5AA16370B	9.16	5LA96011M0300	9.34	5LF28763X	7.9	5LF51B62RW	2.89
5AA16470B	9.16	5LA96211FA300	9.34	5LF28772F	7.9	5LF51B62XW	2.89
5AA17270V	9.18	5LE14501RR	5.62	5LF28772J	7.9	5LF51B71FW	2.89
5AA17370V	9.18	5LE14501UR	5.62	5LF28772X	7.9	5LF51B71HW	2.89
5AA17470V	9.18	5LE14502RR	5.62	5LF28773F	7.9	5LF51B71JW	2.89
5AA26270B	9.17	5LE14502UR	5.62	5LF28773J	7.9	5LF51B71PW	2.89
5AA26271B	9.17	5LE14601RR	5.62	5LF28773X	7.9	5LF51B71QW	2.89
5AA26370B	9.17	5LE14601RR1	5.53, 5.60	5LF41671F	2.130	5LF51B71RW	2.89
5AA26371B	9.17	5LE14601RR2	5.53, 5.60	5LF41671J	2.130	5LF51B72FW	2.89
5AA26470B	9.17	5LE14601UR	5.62	5LF41671P	2.130	5LF51B72HW	2.89
5AA26471B	9.17	5LE14601UR1	5.53, 5.60	5LF41671R	2.130	5LF51B72JW	2.89
5AA27270V	9.19	5LE14601UR2	5.53, 5.60	5LF41671X	2.130	5LF51B72PW	2.89
5AA27271V	9.19	5LE17501ER	5.80	5LF41672F	2.130	5LF51B72RW	2.89
5AA27370V	9.19	5LE78012CR	5.57	5LF41672J	2.130	5LF51B72WW	2.89
5AA27371V	9.19	5LE78012ER	5.57, 5.86	5LF41672P	2.130	5LF51B72XW	2.89
5AA27470V	9.19	5LE78032EG0	5.57, 5.86	5LF41672R	2.130	5LF53661FW	2.48
5AA27471V	9.19	5LE78512ER	5.57, 5.86	5LF41672X	2.130	5LF53661XW	2.48
5AA32000M	9.21	5LE98011CR	5.102	5LF41B61F	2.129	5LF53662FW	2.48
5AA32000ME	9.22	5LE98011ER	5.102	5LF41B61J	2.129	5LF53662JW	2.48
5AA32090E	9.21	5LE98011RR	5.97	5LF41B61P	2.129	5LF53662RW	2.48
5AA32090EE	9.22	5LE98011UR	5.97	5LF41B61R	2.129	5LF53671FW	2.48
5AA32270K	9.21	5LE98111CG	5.102	5LF41B61X	2.129	5LF53671HW	2.48
5AA32270KE	9.22	5LE98111CH	5.102	5LF41B71F	2.129	5LF53671JW	2.48
5AA32290G	9.21	5LE98111CR	5.102	5LF41B71J	2.129	5LF53671PW	2.48
5AA32290GE	9.22	5LE98111EA	5.102	5LF41B71P	2.129	5LF53671QW	2.48
5AA35601X	9.23	5LE98111EG	5.102	5LF41B71R	2.129	5LF53671RW	2.48
5AA35603X	9.23	5LE98111EH	5.102	5LF41B71X	2.129	5LF53671XW	2.48
5AA35604X	9.23	5LE98111ER	5.102	5LF41B72F	2.129	5LF53672FW	2.48
5AA35605X	9.23	5LE98111RA	5.96	5LF41B72J	2.129	5LF53672HW	2.48
5AA35606X	9.23	5LE98111RG	5.97	5LF41B72P	2.129	5LF53672JW	2.48
5AA35607X	9.23	5LE98111RH	5.97	5LF41B72R	2.129	5LF53672PW	2.48
5AA35608X	9.23	5LE98111UA	5.96	5LF41B72X	2.129	5LF53672RW	2.48
5AA35609X	9.23	5LE98111UG	5.97	5LF41W61F	2.128	5LF53672WW	2.48
5AA35610X	9.23	5LE98111UH	5.97	5LF41W61J	2.128	5LF53B61FW	2.47
5AA35611X	9.23	5LE98211RR2	5.96	5LF41W61P	2.128	5LF53B61JW	2.47
5AA40006X	9.45	5LE98211UR2	5.96	5LF41W61R	2.128	5LF53B61PW	2.47
5AA40007X	9.45	5LE98311CR	5.102	5LF41W62F	2.128	5LF53B61XW	2.47
5AA41171D	9.42	5LE98311ER	5.102	5LF41W62P	2.128	5LF53B62FW	2.47
5AA41171K	9.42	5LE98311RR	5.97	5LF41W62R	2.128	5LF53B62JW	2.47
5AA41172D	9.42	5LE98311UR	5.97	5LF41W71F	2.128	5LF53B62RW	2.47
5AA41172K	9.42	5LE98411RR2	5.96	5LF41W71J	2.128	5LF53B71FW	2.47
5AA42171D	9.43	5LE98411UR2	5.96	5LF41W71P	2.128	5LF53B71HW	2.47
5AA42171K	9.43	5LF12671J	2.136	5LF41W71R	2.128	5LF53B71JW	2.47
5AA42172D	9.43	5LF12671P	2.136	5LF41W72F	2.128	5LF53B71PW	2.47
5AA42172K	9.43	5LF12671R	2.136	5LF41W72P	2.128	5LF53B71QW	2.47
5AA43171K	9.44	5LF12672J	2.136	5LF41W72R	2.128	5LF53B71RW	2.47
5AA43171T	9.44	5LF12672P	2.136	5LF51661FW	2.90	5LF53B71XW	2.47
5AA43172K	9.44	5LF12672R	2.136	5LF51661JW	2.90	5LF53B72FW	2.47
5AA43172T	9.44	5LF12673M	2.137	5LF51661RW	2.90	5LF53B72HW	2.47
5AA44171K	9.45	5LF12673Y	2.137	5LF51662FW	2.90	5LF53B72JW	2.47
5AA44171T	9.45	5LF12676Y	2.137	5LF51662JW	2.90	5LF53B72PW	2.47
5AA44172K	9.45	5LF12B61J	2.134	5LF51662PW	2.90	5LF53B72RW	2.47
5AA44172T	9.45	5LF12B62J	2.134	5LF51662RW	2.90	5LF53B72WW	2.47
5AA51000M	9.10	5LF12B62P	2.134	5LF51671FW	2.90	5LF53B72XW	2.47
5AA51001M	9.10	5LF12B62R	2.134	5LF51671HW	2.90	5LF61961F	2.157
5AA52002M	9.11	5LF12B63M	2.135	5LF51671JW	2.90	5LF61961J	2.157
5AA52090E	9.11	5LF12B63Y	2.135	5LF51671PW	2.90	5LF61961P	2.157
5AA52091E	9.11	5LF12B66Y	2.135	5LF51671QW	2.90	5LF61961R	2.157
5AA53092E	9.12	5LF12B71J	2.134	5LF51671RW	2.90	5LF61961X	2.157
5AA53270K	9.12	5LF12B71P	2.134	5LF51672FW	2.90	5LF61971F	2.157
5AA53271K	9.12	5LF12B71R	2.134	5LF51672HW	2.90	5LF61971J	2.157
5AA61000M	9.7	5LF12B72J	2.134	5LF51672JW	2.90	5LF61971P	2.157
5AA62000M	9.7	5LF12B72P	2.134	5LF51672PW	2.90	5LF61971R	2.157
5AA62090E	9.7	5LF12B72R	2.134	5LF51672RW	2.90	5LF61971X	2.157
5LA52822KS28	9.49	5LF12B73M	2.135	5LF51672WW	2.90	5LF61971JW	2.157
5LA52822KS38	9.49	5LF12B73Y	2.135	5LF51961FW	2.161	5LF90001L	2.12, 2.18, 2.158
5LA52822KS58	9.50	5LF12B76Y	2.135	5LF51961JW	2.161	5LF90002L	2.12, 2.18, 2.40, 2.86, 2.158
5LA52822KS68	9.50	5LF28662F	7.8	5LF51961RW	2.161	5LF90003L	2.28, 2.50, 2.86
5LA52922KS28	9.51	5LF28662J	7.8	5LF51961XW	2.161	5LF90005L	2.12, 2.18, 2.40, 2.86, 2.158
5LA52922KS28D	9.53	5LF28662X	7.8	5LF51971FW	2.161	5LF90006L	2.28, 2.50, 2.86
5LA52922KS38	9.51	5LF28663F	7.8	5LF51971JW	2.161	5LF90011	2.131
5LA75771TS0108	7.32	5LF28663J	7.8	5LF51971PW	2.161	5LF90012	2.131
5LA75771TS2108	7.34	5LF28663X	7.8	5LF51971RW	2.161	5LF90014XC	2.125, 2.137, 2.141
5LA90011LA100	9.37	5LF28672F	7.8	5LF51971XW	2.161	5LF90021	2.131
5LA91011FA300	9.33	5LF28672J	7.8	5LF51B61FW	2.89	5LF90024XC	2.125, 2.137, 2.141
5LA91011LA300	9.33	5LF28672X	7.8	5LF51B61JW	2.89	5LF9011	2.131
5LA91111FA308	9.33	5LF28673F	7.8	5LF51B61PW	2.89	5LF9012	2.131
5LA91111FB308	9.33	5LF28673J	7.8	5LF51B61RW	2.89	5LF90210XC	2.137, 2.141
5LA91111LA308	9.33	5LF28673X	7.8	5LF51B62FW	2.89	5LF9084	7.10

Order No.	Page	Order No.	Page	Order No.	Page	Order No.	Page
5LF90910XV	7.10	5UJ10101EB	2.96	5UJ23571E	4.7	5UJ90090XC	5.104
5LF90920X	7.10	5UJ10101UB	2.96	5UJ23571EX1	4.7	5UJ9076	5.44
5LF91202BC	2.158	5UJ10101XB	2.96	5UJ23571EX3	4.5	5UJ90800XB	5.70
5LF91202CC	2.158	5UJ14000XC	5.56	5UJ23571EX4	4.6	5UJ90800XY	5.44, 5.79, 6.66
5LF91203	2.51	5UJ14001CS	5.57	5UJ23572AX1	4.7	5UJ90810XY	5.44, 5.79, 6.66
5LF91203A	2.51	5UJ14001ES	5.57, 5.86	5UJ23572CX1	4.7	5UJ90812XK	5.70
5LF91206XC	2.158	5UJ14001ES1	5.52	5UJ23572CX3	4.5	5UJ90830ED	5.70, 6.64
5LF91213	2.51	5UJ14002XD	5.58, 5.86	5UJ23572EX1	4.7	5UJ90861C1	5.46
5LF91213A	2.51	5UJ14011CS	5.57	5UJ23572EX3	4.5	5UJ90861E1	5.46
5LF91301	2.50	5UJ14011ES	5.57, 5.86	5UJ23574A	4.7	5UJ90862C1	5.46
5LF91301A	2.50	5UJ14011ES1	5.52	5UJ23871C	4.8	5UJ90862E1	5.46
5LF91302	2.12	5UJ14012CB0	5.55	5UJ23871E	4.8	5UJ90862F1	5.50
5LF913020D	2.86	5UJ14012EB0	5.55, 5.85	5UJ23872C	4.8	5UJ90862P1	5.50
5LF91302A	2.12	5UJ14012EB0S	5.55	5UJ23872E	4.8	5UJ90862R1	5.50
5LF91302AC	2.158	5UJ14012XD	5.58, 5.86	5UJ23971C	4.7	5UJ90871C	5.46
5LF91302AD	2.86	5UJ14012XDS	5.58	5UJ23971E	4.7	5UJ90871E	5.46
5LF91302BD	2.40	5UJ14020XD	5.58, 5.86	5UJ23972C	4.7	5UJ90871ED01	5.49
5LF91305B	2.50	5UJ14020XDS	5.58	5UJ23972E	4.7	5UJ90871ED2	5.48
5LF91305BA	2.50	5UJ14021ES1	5.52	5UJ61201ER	5.56	5UJ90871ED3	5.47
5LF91306B	2.50	5UJ14022CB0	5.55	5UJ65701CS	5.56	5UJ90871ED41	5.49
5LF91306BA	2.50	5UJ14022EB0	5.55, 5.85	5UJ65701ES	5.56	5UJ90871F	5.50
5LF91306BC	2.158	5UJ14022EB0S	5.55	5UJ65702CS	5.56	5UJ90871P	5.50
5LF91311	2.50	5UJ14051EB0	5.51, 5.83	5UJ65702ES	5.56	5UJ90871R	5.50
5LF91311A	2.50	5UJ14052XD	5.51, 5.83	5UJ76000Q	5.67	5UJ90871U	5.50
5LF91312	2.12	5UJ14052XDS	5.51, 5.83	5UJ76564X	5.65	5UJ90871X	5.50
5LF91312A	2.12	5UJ14055XD	5.51, 5.83	5UJ76574X	5.65	5UJ90872C	5.46
5LF91312AC	2.158	5UJ14055XDS	5.51, 5.83	5UJ76574X2	5.65	5UJ90872E	5.46
5LF91401	2.50	5UJ14510XD	5.59, 5.61	5UJ765D4X	5.65	5UJ90872ED01	5.49
5LF91401A	2.50	5UJ14510XDS	5.59, 5.61	5UJ76664X	5.66	5UJ90872ED2	5.48
5LF91411	2.50	5UJ14511R	5.59	5UJ76674X	5.66	5UJ90872ED3	5.47
5LF91411A	2.50	5UJ14511RS	5.59	5UJ76674X2	5.66	5UJ90872ED41	5.49
5LF91502BD	2.40	5UJ14511U	5.59	5UJ766D4X	5.66	5UJ90872F	5.50
5LF92003C	2.158	5UJ14511US	5.59	5UJ79161U	2.123	5UJ90872P	5.50
5LF94025	2.51	5UJ14511XD	5.59, 5.61	5UJ79165U	2.123	5UJ90872R	5.50
5LF94025A	2.51	5UJ14511XDS	5.59, 5.61	5UJ79171U	2.123	5UJ90872U	5.50
5LF94026	2.51	5UJ14512U	5.61	5UJ79175U	2.123	5UJ90872X	5.50
5LF94026A	2.51	5UJ14512US	5.61	5UJ79361U	2.124	5UJ90900	5.71, 5.87, 6.64
5LF94111AW	2.158	5UJ14512X	5.61	5UJ79362U	2.124	5UJ909001	5.71, 5.87
5LF941G1SW	2.158	5UJ14512XD	5.62	5UJ79362Y	2.124	5UJ90900XV	5.43
5UJ10001AB	2.96	5UJ14512XDS	5.62	5UJ79365U	2.124	5UJ90900XY	5.44, 5.79
5UJ10001CB	2.96	5UJ14512XS	5.61	5UJ79366U	2.124	5UJ90901	5.71, 5.87, 6.64
5UJ10001EB	2.96	5UJ14521R	5.59	5UJ79371U	2.124	5UJ90910E	5.42, 5.78
5UJ10001UB	2.96	5UJ14521RS	5.59	5UJ79372U	2.124	5UJ90910E1	5.42
5UJ10001XB	2.96	5UJ14521U	5.59	5UJ79372Y	2.124	5UJ90910U	5.42
5UJ10002CB	2.96	5UJ14521US	5.59	5UJ79375U	2.124	5UJ90910U1	5.42
5UJ10002EB	2.96	5UJ14531R	5.59	5UJ79376U	2.124	5UJ90910XC	5.72, 5.87, 6.65
5UJ10002UB	2.96	5UJ14531RS	5.59	5UJ80002XK	2.91, 3.134, 5.44, 5.79, 7.10	5UJ90910XD	5.44
5UJ10010XC	2.96	5UJ14531U	5.59	5UJ80002XW	3.134	5UJ90910XV	5.44, 5.79, 6.64
5UJ10021EK	2.96	5UJ14531US	5.59	5UJ80003XK	2.91, 5.44, 5.79, 7.10	5UJ90911XC	5.72, 5.87, 6.65
5UJ10061A	2.95	5UJ14912R	5.53, 5.60	5UJ80005XK	5.44, 5.79	5UJ90912XC	5.72, 5.87, 6.65
5UJ10061C	2.95	5UJ14912U	5.53, 5.60	5UJ90000ED	5.105	5UJ90920E	5.42, 5.78
5UJ10061E	2.95	5UJ16571CX	2.77	5UJ90010ED	5.103	5UJ90920E1	5.42
5UJ10061H	2.94	5UJ16571EX	2.77	5UJ90010XC	5.106	5UJ90920U	5.42
5UJ10061M	2.94	5UJ16571GX	2.77	5UJ90010XV1	5.103	5UJ90920U1	5.42
5UJ10061Q	2.94	5UJ16671EX	2.77	5UJ90012ED	5.103	5UJ90920XV	5.43
5UJ10061Y	2.94	5UJ17031ES1	5.54, 5.84	5UJ90020ED1	5.103	5UJ90921XC	5.71, 5.87
5UJ10062C	2.95	5UJ23101AW	4.9	5UJ90020XC1	5.105	5UJ90921XC2	5.71, 5.87
5UJ10062E	2.95	5UJ23101CW	4.9	5UJ90020XC2	5.105	5UJ90930E	5.42, 5.78
5UJ10062H	2.94	5UJ23101EW	4.9	5UJ90020XCA	5.105	5UJ90930E1	5.42
5UJ10062Q	2.94	5UJ23102AW	4.9	5UJ90020XCL	5.105	5UJ90930U	5.42
5UJ10071A	2.95	5UJ23102CW	4.9	5UJ90020XCT	5.105	5UJ90930U1	5.42
5UJ10071C	2.95	5UJ23102EW	4.9	5UJ90030ED	5.103	5UJ90930XC	5.71, 5.87, 6.64
5UJ10071E	2.95	5UJ23104AW	4.9	5UJ90030ED1	5.103	5UJ90930XV	5.43
5UJ10071H	2.94	5UJ23201AW	4.8	5UJ90030EDA1	5.103	5UJ90940XV	5.43
5UJ10071M	2.94	5UJ23201CW	4.8	5UJ90030EDA2	5.103	5UJ90960XV	5.43
5UJ10071Q	2.94	5UJ23201EW	4.8	5UJ90030EDA3	5.103	5UJ91301EB	5.98
5UJ10071Y	2.94	5UJ23202AW	4.8	5UJ90030UD1	5.103	5UJ91301UB	5.94
5UJ10072C	2.95	5UJ23202CW	4.8	5UJ90030XC1	5.104	5UJ91361C	5.98
5UJ10072E	2.95	5UJ23202EW	4.8	5UJ90030XC2	5.104	5UJ91361E	5.98
5UJ10072H	2.94	5UJ23204AW	4.8	5UJ90040ED1	5.103	5UJ91361EM	5.98
5UJ10072Q	2.94	5UJ23471A	4.8	5UJ90040XC	5.72, 5.106	5UJ91361EMD	5.98
5UJ100D1C	2.95	5UJ23471C	4.8	5UJ90050ED	5.104	5UJ91361EX03D	5.98
5UJ100D1E	2.95	5UJ23471E	4.8	5UJ90050XC	5.72, 5.106	5UJ91361EX04D	5.98
5UJ100D1H	2.94	5UJ23472A	4.8	5UJ90060XC	5.106	5UJ91361H	5.94
5UJ100D1M	2.94	5UJ23472C	4.8	5UJ90060XC1	5.104	5UJ91361HM	5.94
5UJ100D1Q	2.94	5UJ23472E	4.8	5UJ90060XC1S	5.104	5UJ91361HMD	5.94
5UJ100D1Y	2.94	5UJ23474A	4.8	5UJ90060XC2	5.104	5UJ91361HX03D	5.94
5UJ100D2H	2.94	5UJ23571A	4.7	5UJ90070XC1	5.105	5UJ91361HX04D	5.94
5UJ100D2Q	2.94	5UJ23571C	4.7	5UJ90070XC1S	5.105	5UJ91361Q	5.94
5UJ10101AB	2.96	5UJ23571CX1	4.7	5UJ90080XC1	5.105	5UJ91361QM	5.94
5UJ10101CB	2.96	5UJ23571CX3	4.5	5UJ90080XC1S	5.105	5UJ91361QMD	5.94

Order No.	Page	Order No.	Page	Order No.	Page	Order No.	Page
5UJ91361QX03D	5.94	5UJ93371QX03D	5.95	5UJ96920E1	5.42	5LM52262PS	2.60
5UJ91361QX04D	5.94	5UJ93371QX04D	5.95	5UJ96920U	5.42	5LM52262PW	2.60
5UJ91362H	5.94	5UJ93371UX11	2.43	5UJ96920U1	5.42	5LM52262RS	2.60
5UJ91362Q	5.94	5UJ93371UX12	2.43	5UJ96920XV	5.43	5LM52262RW	2.60
5UJ91371C	5.98	5UJ93371XX11	2.43	5UJ96930E	5.42	5LM52262YS	2.61
5UJ91371E	5.98	5UJ933D1H	5.95	5UJ96930E1	5.42	5LM52272MS	2.60
5UJ91371EM	5.98	5UJ933D1HM	5.95	5UJ96930U	5.42	5LM52272NS	2.60
5UJ91371EMD	5.98	5UJ933D1HMD	5.95	5UJ96930U1	5.42	5LM52272PS	2.60
5UJ91371EX03D	5.98	5UJ933D1HX03D	5.95	5UJ96930XV	5.43	5LM52272PW	2.60
5UJ91371EX04D	5.98	5UJ933D1HX04D	5.95	5UJ96940XV	5.43	5LM52272RS	2.60
5UJ91371H	5.94	5UJ933D1Q	5.95	5UJ96960XV	5.43	5LM52272RW	2.60
5UJ91371HM	5.94	5UJ933D1QM	5.95	5UJ97171H	5.69	5LM52272YS	2.61
5UJ91371HMD	5.94	5UJ933D1QMD	5.95	5UJ97171HS	5.69	5LM52277LS	2.61
5UJ91371HX03D	5.94	5UJ933D1QX03D	5.95	5UJ97171J	5.69	5LM522D2MS	2.60
5UJ91371HX04D	5.94	5UJ933D1QX04D	5.95	5UJ97171JS	5.69	5LM522D2NS	2.60
5UJ91371Q	5.94	5UJ933D1UX11	2.43	5LK91300	5.71, 5.87, 5.104	5LM522D2PS	2.60
5UJ91371QM	5.94	5UJ933D1UX12	2.43	5LL92003E	2.51	5LM522D2PW	2.60
5UJ91371QMD	5.94	5UJ93401EB	5.101	5LL92005E	2.51	5LM522D2RS	2.60
5UJ91371QX03D	5.94	5UJ93461C	5.101	5LM37501S1	2.31	5LM522D2RW	2.60
5UJ91371QX04D	5.94	5UJ93461E	5.101	5LM37562RL1S1	2.31	5LM52362FS	2.10
5UJ91372H	5.94	5UJ93461EM	5.101	5LM37562XL1S1	2.31	5LM52362JS	2.10
5UJ91372Q	5.94	5UJ93461EMD	5.101	5LM37572RL1S1	2.31	5LM52362NS	2.10
5UJ913D1H	5.94	5UJ93471C	5.101	5LM37572XL1S1	2.31	5LM52362PS	2.10
5UJ913D1HM	5.94	5UJ93471E	5.101	5LM375D2RL1S1	2.31	5LM52362PW	2.10
5UJ913D1HMD	5.94	5UJ93471EM	5.101	5LM375D2XL1S1	2.31	5LM52362RS	2.10
5UJ913D1HX03D	5.94	5UJ93471EMD	5.101	5LM380D1S1L1	2.7	5LM52362RW	2.10
5UJ913D1HX04D	5.94	5UJ93562U	2.45	5LM51162NS	2.106	5LM52362XS	2.10
5UJ913D1Q	5.94	5UJ93562UX02	2.45	5LM51162NW	2.106	5LM52372FS	2.10
5UJ913D1QM	5.94	5UJ93572U	2.45	5LM51172NS	2.106	5LM52372JS	2.10
5UJ913D1QMD	5.94	5UJ93572UX02	2.45	5LM51172NW	2.106	5LM52372NS	2.10
5UJ913D1QX03D	5.94	5UJ96171H	5.68	5LM51172TS	2.107	5LM52372PS	2.10
5UJ913D1QX04D	5.94	5UJ96171HS	5.68	5LM51172TW	2.107	5LM52372PW	2.10
5UJ913D2H	5.94	5UJ96171J	5.68	5LM51177LS	2.107	5LM52372RS	2.10
5UJ913D2Q	5.94	5UJ96171JS	5.68	5LM51177LW	2.107	5LM52372RW	2.10
5UJ91401EB	5.100	5UJ96800XB	5.70	5LM511D2NS	2.106	5LM52372XS	2.10
5UJ91461C	5.100	5UJ96812XK	5.70	5LM511D2NW	2.106	5LM523D2FS	2.10
5UJ91461E	5.100	5UJ96830ED	5.70, 6.64	5LM51262MS	2.106	5LM523D2JS	2.10
5UJ91461EMD	5.100	5UJ96861C1	5.46	5LM51262MW	2.106	5LM523D2NS	2.10
5UJ91461EX03D	5.100	5UJ96861E1	5.46	5LM51262PS	2.106	5LM523D2PS	2.10
5UJ91461EX04D	5.100	5UJ96861F1	5.50	5LM51262PW	2.106	5LM523D2RS	2.10
5UJ91471C	5.100	5UJ96861P1	5.50	5LM51262RS	2.106	5LM523D2XS	2.10
5UJ91471E	5.100	5UJ96861R1	5.50	5LM51262RW	2.106	5LM530110S	2.17
5UJ91471EM	5.100	5UJ96861U1	5.50	5LM51262YS	2.107	5LM530110W	2.17
5UJ91471EMD	5.100	5UJ96861X1	5.50	5LM51262YW	2.107	5LM530120S	2.17
5UJ91471EX03D	5.100	5UJ96862C1	5.46	5LM51272MS	2.106	5LM530120W	2.17
5UJ91471EX04D	5.100	5UJ96862E1	5.46	5LM51272MW	2.106	5LM530130S	2.17
5UJ93301EB	5.99	5UJ96862F1	5.50	5LM51272PS	2.106	5LM530130W	2.17
5UJ93301UB	5.95	5UJ96862P1	5.50	5LM51272PW	2.106	5LM54061F	2.16
5UJ93361C	5.99	5UJ96862R1	5.50	5LM51272RS	2.106	5LM54061J	2.16
5UJ93361E	5.99	5UJ96862U1	5.50	5LM51272RW	2.106	5LM54061K	2.16
5UJ93361EM	5.99	5UJ96862X1	5.50	5LM51272YS	2.107	5LM54061N	2.16
5UJ93361EMD	5.99	5UJ96871C	5.46	5LM51272YW	2.107	5LM54061P	2.16
5UJ93361EX03D	5.99	5UJ96871E	5.46	5LM512D2MS	2.106	5LM54061R	2.16
5UJ93361EX04D	5.99	5UJ96871ED01	5.49	5LM512D2MW	2.106	5LM54061X	2.16
5UJ93361H	5.95	5UJ96871ED2	5.48	5LM512D2PS	2.106	5LM54071F	2.16
5UJ93361HM	5.95	5UJ96871ED3	5.47	5LM512D2PW	2.106	5LM54071J	2.16
5UJ93361HMD	5.95	5UJ96871F	5.50	5LM512D2RS	2.106	5LM54071K	2.16
5UJ93361HX03D	5.95	5UJ96871P	5.50	5LM512D2RW	2.106	5LM54071N	2.16
5UJ93361HX04D	5.95	5UJ96871R	5.50	5LM512D2YS	2.107	5LM54071P	2.16
5UJ93361Q	5.95	5UJ96871U	5.50	5LM512D2YW	2.107	5LM54071R	2.16
5UJ93361QM	5.95	5UJ96871X	5.50	5LM52162NS	2.14, 2.58	5LM54071X	2.16
5UJ93361QMD	5.95	5UJ96872C	5.46	5LM52162PS	2.14, 2.58	5LM540D1F	2.16
5UJ93361QX03D	5.95	5UJ96872E	5.46	5LM52162PW	2.14, 2.58	5LM540D1J	2.16
5UJ93361QX04D	5.95	5UJ96872ED01	5.49	5LM52162RS	2.14, 2.58	5LM540D1N	2.16
5UJ93361UX11	2.43	5UJ96872ED2	5.48	5LM52162RW	2.14, 2.58	5LM540D1P	2.16
5UJ93361UX12	2.43	5UJ96872ED3	5.47	5LM52162YS	2.15, 2.59	5LM540D1R	2.16
5UJ93361XX11	2.43	5UJ96872F	5.50	5LM52172MS	2.14, 2.58	5LM540D1X	2.16
5UJ93371C	5.99	5UJ96872P	5.50	5LM52172NS	2.14, 2.58	5LM59101	2.108
5UJ93371E	5.99	5UJ96872R	5.50	5LM52172PS	2.14, 2.58	5LM59102	2.108
5UJ93371EM	5.99	5UJ96872U	5.50	5LM52172PW	2.14, 2.58	5LM59103	2.108
5UJ93371EMD	5.99	5UJ96872X	5.50	5LM52172RS	2.14, 2.58	5LM59104	2.108
5UJ93371EX03D	5.99	5UJ96900	5.71	5LM52172RW	2.14, 2.58	5LM59201	2.63
5UJ93371EX04D	5.99	5UJ96900XV	5.43	5LM52172YS	2.15, 2.59	5LM59202	2.63
5UJ93371H	5.95	5UJ96901	5.71	5LM52177LS	2.59	5LM593010S	2.19
5UJ93371HM	5.95	5UJ96902	5.72	5LM521D2MS	2.14, 2.58	5LM593010W	2.19
5UJ93371HMD	5.95	5UJ96910E	5.42	5LM521D2NS	2.14, 2.58	5LM59301A	2.12
5UJ93371HX03D	5.95	5UJ96910E1	5.42	5LM521D2PS	2.14, 2.58	5LM593020S	2.19
5UJ93371HX04D	5.95	5UJ96910U	5.42	5LM521D2PW	2.14, 2.58	5LM593020W	2.19
5UJ93371Q	5.95	5UJ96910U1	5.42	5LM521D2RS	2.14, 2.58	5LM593040S	2.18
5UJ93371QM	5.95	5UJ96910XD	5.44	5LM52262MS	2.60	5LM593040W	2.18
5UJ93371QMD	5.95	5UJ96920E	5.42	5LM52262NS	2.60	5LM593060S	2.18

Order No.	Page	Order No.	Page	Order No.	Page	Order No.	Page
5LM593060W	2.18	5LP94024	2.18, 2.51, 5.43	5LR14472FA61	3.128	5LR414D2VA61	3.103
5LM59307	2.18	5LP94024A	2.18, 2.51, 5.43	5LR14472GA61	3.128	5LR41561VA61	3.115
5LM593080S	2.18	5LR0003RA	3.134	5LR14472VA61	3.128	5LR41571VA61	3.115
5LM593080W	2.18	5LR0003SA	3.134	5LR144D1VA61	3.128	5LR415D1VA61	3.115
5LM593090S	2.18	5LR0008GA	3.68	5LR144D2VA61	3.128	5LR41661VA61	3.114
5LM593090W	2.18	5LR0008HA	3.68	5LR21161VA63	3.15	5LR41662VA61	3.114
5LM593092S	2.18	5LR0008JA	3.68	5LR21161VA64	3.15	5LR41671VA61	3.114
5LM593093S	2.18	5LR11161GA51	3.120	5LR21171GA63	3.15	5LR41672VA61	3.114
5LM59311A	2.12	5LR11161VA51	3.120	5LR21171GA64	3.15	5LR416D1VA61	3.114
5LM593120S	2.19	5LR11171FA51	3.120	5LR21171VA63	3.15	5LR416D2VA61	3.114
5LM593120W	2.19	5LR11171GA51	3.120	5LR21171VA6302	3.16	5LR41861VA61	3.105
5LM62162MS	2.62	5LR11171VA51	3.120	5LR21171VA64	3.15	5LR41862KA6100N	3.109
5LM62162PS	2.62	5LR111D1GA51	3.120	5LR21171VA6402	3.16	5LR41862VA61	3.105
5LM62162RS	2.62	5LR111D1VA51	3.120	5LR211D1VA63	3.15	5LR41862VA6100N	3.109
5LM62162YS	2.62	5LR11261LA51	3.121	5LR211D1VA64	3.15	5LR41871KA61	3.105
5LM62172MS	2.62	5LR11261VA61	3.123	5LR21461VA63	3.18	5LR41871VA61	3.105
5LM62172PS	2.62	5LR11262LA51	3.121	5LR21461VA64	3.18	5LR41871VA6102	3.106
5LM62172RS	2.62	5LR11262VA61	3.123	5LR21462VA63	3.18	5LR41872KA61	3.105
5LM62172YS	2.62	5LR11271FA51	3.121	5LR21462VA64	3.18	5LR41872KA6100N	3.109
5LM62262PS	2.63	5LR11271GA51	3.121	5LR21471GA63	3.18	5LR41872VA61	3.105
5LM62262RS	2.63	5LR11271GA61	3.123	5LR21471GA64	3.18	5LR41872VA6100N	3.109
5LM62272PS	2.63	5LR11271LA51	3.121	5LR21471VA63	3.18	5LR41872VA6102	3.106
5LM62272RS	2.63	5LR11271VA5102	3.122	5LR21471VA6302	3.19	5LR418D1VA61	3.105
5LM62362FS	2.11	5LR11271VA61	3.123	5LR21471VA64	3.18	5LR418D2KA6100N	3.109
5LM62362JS	2.11	5LR11271VA6102	3.124	5LR21471VA6402	3.19	5LR418D2VA61	3.105
5LM62362PS	2.11	5LR11272FA51	3.121	5LR21472GA63	3.18	5LR418D2VA6100N	3.109
5LM62362RS	2.11	5LR11272GA51	3.121	5LR21472GA64	3.18	5LR42101HA51	3.94
5LM62362XS	2.11	5LR11272GA61	3.123	5LR21472VA63	3.18	5LR42101HA61	3.98
5LM62372FS	2.11	5LR11272LA51	3.121	5LR21472VA6302	3.19	5LR42101SA51	3.96
5LM62372JS	2.11	5LR11272VA5102	3.122	5LR21472VA64	3.18	5LR42101SA61	3.100
5LM62372PS	2.11	5LR11272VA61	3.123	5LR21472VA6402	3.19	5LR42401HA61	3.99
5LM62372RS	2.11	5LR11272VA6102	3.124	5LR214D1VA63	3.18	5LR42401JA51	3.95
5LM62372XS	2.11	5LR112D1LA51	3.121	5LR214D1VA64	3.18	5LR42401RA61	3.101
5LM623D2FS	2.11	5LR112D1VA61	3.123	5LR214D2VA63	3.18	5LR42401SA51	3.97
5LM623D2JS	2.11	5LR112D2LA51	3.121	5LR214D2VA64	3.18	5LR42501JA61	3.111
5LM623D2PS	2.11	5LR112D2VA61	3.123	5LR22181GA63	3.17	5LR42501SA61	3.113
5LM623D2RS	2.11	5LR11461VA61	3.125	5LR22181GA64	3.17	5LR42601HA61	3.110
5LM623D2XS	2.11	5LR11462VA61	3.125	5LR22181HA63	3.17	5LR42601RA61	3.112
5LM70100	2.155	5LR11471FA61	3.125	5LR22181HA64	3.17	5LR43461VA61	3.107
5LM70161C	2.151	5LR11471GA61	3.125	5LR35771VA61	3.138	5LR43462VA61	3.107
5LM70161CX1	2.154	5LR11471VA61	3.125	5LR35762LA61	3.138	5LR43471KA61	3.107
5LM70161CX2	2.154	5LR11471VA6102	3.126	5LR35771FA61	3.138	5LR43471VA61	3.107
5LM70161E	2.151	5LR11472FA61	3.125	5LR35771GA61	3.138	5LR43472KA61	3.107
5LM70161EX1	2.154	5LR11472GA61	3.125	5LR35771VA61	3.138	5LR43472VA61	3.107
5LM70161EX2	2.154	5LR11472VA61	3.125	5LR35771VA6102	3.139	5LR434D1VA61	3.107
5LM70161F	2.151	5LR11472VA6102	3.126	5LR35772FA61	3.138	5LR434D2VA61	3.107
5LM70161J	2.151	5LR114D1VA61	3.125	5LR35772GA61	3.138	5LR44461VA61	3.108
5LM70161P	2.151	5LR114D2VA61	3.125	5LR35772LA61	3.138	5LR44462VA61	3.108
5LM70161R	2.151	5LR11701FD41	3.83	5LR357D1VA61	3.138	5LR44471KA61	3.108
5LM70161X	2.151	5LR11701LF41	3.81	5LR36761VA61	3.140	5LR44471VA61	3.108
5LM70171C	2.151	5LR11801FD31	3.79	5LR36762LA61	3.140	5LR44472KA61	3.108
5LM70171CX1	2.154	5LR11801LF31	3.77	5LR36771FA61	3.140	5LR44472VA61	3.108
5LM70171CX2	2.154	5LR12201JA51	3.118	5LR36771GA61	3.140	5LR444D1VA61	3.108
5LM70171E	2.151	5LR12201SA51	3.119	5LR36771VA61	3.140	5LR444D2VA61	3.108
5LM70171EX1	2.154	5LR12701FD41	3.84	5LR36771VA6102	3.141	5LR61061SA11AA	3.43
5LM70171EX2	2.154	5LR12701LF41	3.82	5LR36772FA61	3.140	5LR61061SA11AE	3.42
5LM70171F	2.151	5LR12801FD31	3.80	5LR36772GA61	3.140	5LR61061SA11AF	3.42
5LM70171J	2.151	5LR12801FD36	3.86	5LR36772LA61	3.140	5LR61061TA11AA	3.43
5LM70171P	2.151	5LR12801FD37	3.88	5LR367D1VA61	3.140	5LR61061TA11AE	3.42
5LM70171R	2.151	5LR12801FD38	3.88	5LR37761VA61	3.142	5LR61061TA11AF	3.42
5LM70171X	2.151	5LR12801FD39	3.90	5LR37762LA61	3.142	5LR61071SA11AA	3.43
5LM70261C	2.148	5LR12801LF31	3.78	5LR37771FA61	3.142	5LR61071SA11AE	3.42
5LM70261E	2.148	5LR12801LF36	3.85	5LR37771GA61	3.142	5LR61071SA11AE02	3.44
5LM70261F	2.148	5LR12801LF37	3.87	5LR37771VA61	3.142	5LR61071SA11AF	3.42
5LM70261J	2.148	5LR12801LF38	3.87	5LR37771VA6102	3.143	5LR61071SA11AF02	3.44
5LM70261P	2.148	5LR12801LF39	3.89	5LR37772FA61	3.142	5LR61071SA12AB	3.56
5LM70261R	2.148	5LR13461VA61	3.127	5LR37772GA61	3.142	5LR61071SA12AC	3.56
5LM70261X	2.148	5LR13462VA61	3.127	5LR37772LA61	3.142	5LR61071SA12DE	3.53
5LM70271C	2.148	5LR13471FA61	3.127	5LR377D1VA61	3.142	5LR61071SA13KJ	3.46
5LM70271E	2.148	5LR13471GA61	3.127	5LR41161VA61	3.102	5LR61071SA13LJ	3.46
5LM70271F	2.148	5LR13471VA61	3.127	5LR41171VA61	3.102	5LR61071SA13MJ	3.46
5LM70271J	2.148	5LR13472FA61	3.127	5LR411D1VA61	3.102	5LR61071SA13NJ	3.46
5LM70271P	2.148	5LR13472GA61	3.127	5LR41461VA61	3.103	5LR61071SA13VA	3.52
5LM70271R	2.148	5LR13472VA61	3.127	5LR41462VA61	3.103	5LR61071SA13WJ	3.46
5LM70271X	2.148	5LR134D1VA61	3.127	5LR41471KA61	3.103	5LR61071SA14CE	3.54
5LM82001	2.155	5LR134D2VA61	3.127	5LR41471VA61	3.103	5LR61071SA14EE	3.45
5LP90000XC	2.131	5LR14461VA61	3.128	5LR41471VA6102	3.104	5LR61071SA14EF	3.45
5LP90010XC	2.131	5LR14462VA61	3.128	5LR41472KA61	3.103	5LR61071SA14VA	3.51
5LP91202X	5.43	5LR14471FA61	3.128	5LR41472VA61	3.103	5LR61071SA15CE	3.55
5LP91212X	5.43	5LR14471GA61	3.128	5LR41472VA6102	3.104	5LR61071SA15CF	3.55
5LP91303S	2.12, 2.28, 2.50, 2.86	5LR14471VA61	3.128	5LR414D1VA61	3.103	5LR61071SA15DE	3.55

Order No.	Page	Order No.	Page	Order No.	Page	Order No.	Page
5LR61071SA15DF	3.55	5LR61271SA45CF	3.11	5LR926800G	3.13, 3.25	5LR9545CEF	3.131
5LR61071SA16AE	3.57	5LR61271SA45DF	3.11	5LR926800M	3.13, 3.25	5LR9545CEJ	3.130
5LR61071SA16AF	3.57	5LR61271TA31AE	3.6	5LR926800N	3.13, 3.25	5LR9545CEK	3.130
5LR61071SA16BE	3.57	5LR61271TA31AE02	3.7	5LR926800P	3.13, 3.25	5LR9545CEL	3.130
5LR61071SA16BF	3.57	5LR61271TA32DE	3.10	5LR92688BV	3.13	5LR9545CHP	3.129
5LR61071SA16CE	3.58	5LR61271TA33KJ	3.9	5LR94151AB	3.129	5LR95463DV00	3.23, 3.132
5LR61071SA16CF	3.58	5LR61271TA33LJ	3.9	5LR94161AA	3.20, 3.129	5LR95463DV01	3.23, 3.132
5LR61071SA16DE	3.58	5LR61271TA33MJ	3.9	5LR94161AB	3.20, 3.129	5LR95463DV11	3.23, 3.132
5LR61071SA16DF	3.58	5LR61271TA33NJ	3.9	5LR94161AD	3.20, 3.129	5LR95463DV12	3.23, 3.132
5LR61071SA16EE	3.59	5LR61271TA33WJ	3.9	5LR94361AB	3.144	5LR95463DV21	3.23, 3.132
5LR61071SA16EF	3.59	5LR61271TA34EE	3.8	5LR94363DK	3.144	5LR95463DV41	3.23, 3.132
5LR61071SA17KF	3.47	5LR61271TA35CE	3.11	5LR94364AB	3.144	5LR95463DV42	3.23, 3.132
5LR61071SA17SF	3.49	5LR61271TA35DE	3.11	5LR94365CH	3.144	5LR95463DV43	3.23, 3.132
5LR61071SA18KF	3.48	5LR61271TA41AF	3.6	5LR9446ADT	3.22, 3.131	5LR95463DV81	3.23, 3.132
5LR61071SA18SF	3.50	5LR61271TA41AF02	3.7	5LR9446AEQ	3.21, 3.130	5LR95463DV82	3.23, 3.132
5LR61071TA11AA	3.43	5LR61271TA42DE	3.10	5LR9446AFQ	3.21, 3.130	5LR95463DV83	3.23, 3.132
5LR61071TA11AE	3.42	5LR61271TA43KJ	3.9	5LR9446BDT	3.22, 3.131	5LR9546ADN	3.23, 3.132
5LR61071TA11AE02	3.44	5LR61271TA43LJ	3.9	5LR9446BEQ	3.21, 3.130	5LR9546AEA	3.22, 3.131
5LR61071TA11AF	3.42	5LR61271TA43MJ	3.9	5LR9446BFQ	3.21, 3.130	5LR9546AEB	3.22, 3.131
5LR61071TA11AF02	3.44	5LR61271TA43NJ	3.9	5LR9446CDT	3.22, 3.131	5LR9546AEE	3.22, 3.131
5LR61071TA12AB	3.56	5LR61271TA43WJ	3.9	5LR9446CEQ	3.21, 3.130	5LR9546AEF	3.22, 3.131
5LR61071TA12AC	3.56	5LR61271TA44EF	3.8	5LR9446CFQ	3.21, 3.130	5LR9546AEJ	3.21, 3.130
5LR61071TA12DE	3.53	5LR61271TA45CF	3.11	5LR94681CE	3.12, 3.60	5LR9546AEK	3.21, 3.130
5LR61071TA13KJ	3.46	5LR61271TA45DF	3.11	5LR94683DT	3.12, 3.60	5LR9546AEL	3.21, 3.130
5LR61071TA13LJ	3.46	5LR612D1SA31AE	3.6	5LR94684CE	3.12, 3.60	5LR9546AHP	3.21, 3.129
5LR61071TA13MJ	3.46	5LR612D1SA41AF	3.6	5LR94685CM	3.13	5LR9546BDN	3.23, 3.132
5LR61071TA13NJ	3.46	5LR612D1TA31AE	3.6	5LR94685CN	3.13	5LR9546BEA	3.22, 3.131
5LR61071TA13VA	3.52	5LR612D1TA41AF	3.6	5LR94685EE	3.12, 3.60	5LR9546BEB	3.22, 3.131
5LR61071TA13WJ	3.46	5LR7000B	3.68	5LR94685QM	3.13	5LR9546BEE	3.22, 3.131
5LR61071TA14CE	3.54	5LR7000F	3.68	5LR94685RM	3.13	5LR9546BEF	3.22, 3.131
5LR61071TA14EE	3.45	5LR7000G	3.68	5LR94685SM	3.13	5LR9546BEJ	3.21, 3.130
5LR61071TA14EF	3.45	5LR7000I	3.68	5LR94685TM	3.13	5LR9546BEK	3.21, 3.130
5LR61071TA14VA	3.51	5LR7000U	3.68	5LR94685UM	3.13, 3.60	5LR9546BEL	3.21, 3.130
5LR61071TA15CE	3.55	5LR7000W	3.68	5LR94688CE	3.12, 3.60	5LR9546BHP	3.21, 3.129
5LR61071TA15CF	3.55	5LR7003RA	3.68	5LR95153EA	3.133	5LR9546CDN	3.23, 3.132
5LR61071TA15DE	3.55	5LR7003SA	3.68	5LR95153EB	3.133	5LR9546CEA	3.22, 3.131
5LR61071TA15DF	3.55	5LR71101HA51	3.65	5LR95153EC	3.133	5LR9546CEB	3.22, 3.131
5LR61071TA16AE	3.57	5LR71101JA51	3.65	5LR95153ED	3.133	5LR9546CEE	3.22, 3.131
5LR61071TA16AF	3.57	5LR71101SA51	3.65	5LR95153EE	3.133	5LR9546CEF	3.22, 3.131
5LR61071TA16BE	3.57	5LR71401HA51	3.64	5LR95153EF	3.133	5LR9546CEJ	3.21, 3.130
5LR61071TA16BF	3.57	5LR71401JA51	3.64	5LR95153EG	3.133	5LR9546CEK	3.21, 3.130
5LR61071TA16CE	3.58	5LR73101HA51	3.66	5LR95153EH	3.133	5LR9546CEL	3.21, 3.130
5LR61071TA16CF	3.58	5LR73101JA51	3.66	5LR95153EJ	3.133	5LR9546CHP	3.21, 3.129
5LR61071TA16DE	3.58	5LR73101SA51	3.66	5LR95153EK	3.133	5LS17571EB0	5.80
5LR61071TA16DF	3.58	5LR73501HA51	3.67	5LR95153EL	3.133	5LS17572EB0	5.80
5LR61071TA16EE	3.59	5LR73501JA51	3.67	5LR95153ES	3.132	5LS17671EB0	5.80
5LR61071TA16EF	3.59	5LR91100BQ	3.135	5LR95153ES	3.132	5LS20901CD	6.51
5LR61071TA17LF	3.47	5LR91100BR	3.135	5LR95156ES	3.132	5LS20901ED	6.51
5LR61071TA17SF	3.49	5LR91150BA	3.135	5LR95163EA	3.24, 3.133	5LS20901ED	6.51
5LR61071TA18LF	3.48	5LR91150BC	3.135	5LR95163EB	3.24, 3.133	5LS21501AG	6.50
5LR61071TA18SF	3.50	5LR91150BD	3.135	5LR95163EC	3.24, 3.133	5LS21501CB	6.50
5LR610D1SA11AA	3.43	5LR91150BF	3.135	5LR95163ED	3.24, 3.133	5LS21501CG	6.50
5LR610D1SA11AE	3.42	5LR91154BG	3.135	5LR95163EE	3.24, 3.133	5LS21501EB	6.50
5LR610D1SA11AF	3.42	5LR91160BA	3.135, 3.145	5LR95163EF	3.24, 3.133	5LS21501EG	6.50
5LR610D1TA11AA	3.43	5LR91160BC	3.135, 3.145	5LR95163EG	3.24, 3.133	5LS21511CB	6.50
5LR610D1TA11AE	3.42	5LR91160BD	3.135	5LR95163EH	3.24, 3.133	5LS21511CG	6.51
5LR610D1TA11AF	3.42	5LR91160BE	3.135	5LR95163EJ	3.24, 3.133	5LS21511EB	6.50
5LR61261SA31AE	3.6	5LR91160BF	3.135	5LR95163EK	3.24, 3.133	5LS21511EG	6.51
5LR61261SA41AF	3.6	5LR91160BG	3.135	5LR95163EL	3.24, 3.133	5LS21521CB	6.50
5LR61261TA31AE	3.6	5LR91164BG	3.135	5LR95163ES	3.23, 3.132	5LS21521EB	6.50
5LR61261TA41AF	3.6	5LR91220BC	3.91	5LR95166ES	3.23, 3.132	5LS21601EK	6.51
5LR61271SA31AE	3.6	5LR91220BE	3.91	5LR95354CP	3.132	5LS21601XK	6.50, 6.51
5LR61271SA31AE02	3.7	5LR91240BC	3.91	5LR95364CP	3.23, 3.132, 3.145	5LS21602XK	6.50
5LR61271SA32DE	3.10	5LR91240BE	3.91	5LR9545AEA	3.131	5LS21610CB1	6.50
5LR61271SA33KJ	3.9	5LR91360BB	3.145	5LR9545AEB	3.131	5LS21610EB1	6.50
5LR61271SA33LJ	3.9	5LR91360BD	3.145	5LR9545AEE	3.131	5LS21671A	6.49
5LR61271SA33MJ	3.9	5LR91364BG	3.145	5LR9545AEF	3.131	5LS21671CT1	6.49
5LR61271SA33NJ	3.9	5LR91680BC	3.61	5LR9545AEJ	3.130	5LS21671ET1	6.49
5LR61271SA33WJ	3.9	5LR91680BD	3.61	5LR9545AEK	3.130	5LS21672CT1	6.49
5LR61271SA34EE	3.8	5LR91684BG	3.61	5LR9545AEL	3.130	5LS21672ET1	6.49
5LR61271SA35CE	3.11	5LR92204BS	3.13, 3.25	5LR9545AHP	3.129	5LS21701	6.47
5LR61271SA35DE	3.11	5LR92204BT	3.13, 3.25	5LR9545BEA	3.131	5LS21701JG	6.46
5LR61271SA41AF	3.6	5LR92208BS	3.13, 3.25	5LR9545BEB	3.131	5LS21701JK	6.46
5LR61271SA41AF02	3.7	5LR92208BT	3.13, 3.25	5LR9545BEE	3.131	5LS21701XG	6.46
5LR61271SA42DE	3.10	5LR92264BA	3.25	5LR9545BEF	3.131	5LS21701XK	6.46
5LR61271SA43KJ	3.9	5LR92264BB	3.25	5LR9545BEJ	3.130	5LS21702	6.46
5LR61271SA43LJ	3.9	5LR92264BE	3.25	5LR9545BEK	3.130	5LS21711JG	6.46
5LR61271SA43MJ	3.9	5LR92264BF	3.25	5LR9545BEL	3.130	5LS21711XG	6.46
5LR61271SA43NJ	3.9	5LR92268BA	3.25	5LR9545BHP	3.129	5LS21771F	6.45
5LR61271SA43WJ	3.9	5LR92268BE	3.25	5LR9545CEA	3.131	5LS21771J	6.45
5LR61271SA44EF	3.8	5LR92268BF	3.25	5LR9545CEB	3.131	5LS21771P	6.45
				5LR9545CEE	3.131	5LS21771R	6.45

Order No.	Page	Order No.	Page	Order No.	Page	Order No.	Page
5LS21771X	6.45	5LS32372EY	6.20	5LS41261A	6.38	5LS42272C	6.38
5LS21772F	6.45	5LS32471E	6.10	5LS41261C	6.38	5LS42272CC05	6.40
5LS21772J	6.45	5LS32472E	6.10	5LS41261CA0007	6.38	5LS42272E	6.38
5LS21772P	6.45	5LS32571E	6.10	5LS41261E	6.38	5LS42272EC05	6.40
5LS21772R	6.45	5LS32572E	6.10	5LS41261EA0007	6.38	5LS42272F	6.36
5LS21772X	6.45	5LS32671E	6.9	5LS41261J	6.36	5LS42272JE	6.36
5LS22871C	6.27	5LS32672E	6.9	5LS41261P	6.36	5LS42272L	6.37
5LS22871CF3	6.61	5LS32771E	6.8	5LS41261X	6.36	5LS42272M	6.36
5LS22871CF4	6.61	5LS32772E	6.8	5LS41262C	6.38	5LS42272P	6.36
5LS22871CY	6.30	5LS32861E	6.6	5LS41262CA0007	6.38	5LS42272R	6.36
5LS22871E	6.27	5LS32862E	6.7	5LS41262E	6.38	5LS42272W	6.37
5LS22871EF3	6.61	5LS32871E	6.6	5LS41262EA0007	6.38	5LS42272Y	6.36
5LS22871EF4	6.61	5LS32872E	6.7	5LS41262F	6.36	5LS422D1C	6.38
5LS22872CF3	6.61	5LS328D1E	6.6	5LS41262P	6.36	5LS422D1E	6.38
5LS22872CF4	6.61	5LS328D2E	6.7	5LS41271A	6.38	5LS422D1F	6.36
5LS22872E	6.27	5LS32901AW	6.33	5LS41271B	6.37	5LS422D1J	6.36
5LS22872EF3	6.61	5LS32901CW	6.33	5LS41271C	6.38	5LS422D1X	6.36
5LS22872EF4	6.61	5LS32901CWT1	6.33	5LS41271CA0007	6.38	5LS422D2E	6.38
5LS22971C	6.27	5LS32901EW	6.33	5LS41271E	6.38	5LS42771C	6.39
5LS22971CF3004	6.61	5LS32901EWT1	6.33	5LS41271EA0007	6.38	5LS42771E	6.39
5LS22971CF4004	6.61	5LS32902CW	6.33	5LS41271EA04	6.40	5LS42771EA0004	6.39
5LS22971CY	6.30	5LS32902CWT1	6.33	5LS41271EA05	6.40	5LS42772E	6.39
5LS22971E	6.27	5LS32902EW	6.33	5LS41271F	6.36	5LS42772EA0004	6.39
5LS22971EF3004	6.61	5LS32902EWT1	6.33	5LS41271H	6.37	5LS427D2C	6.39
5LS22971EF4004	6.61	5LS32911AW	6.33	5LS41271J	6.36	5LS427D2E	6.39
5LS22972CF3004	6.61	5LS32911CW	6.33	5LS41271L	6.37	5LS44001	6.42
5LS22972CF4004	6.61	5LS32911EW	6.33	5LS41271M	6.36	5LS44002	6.43, 6.65
5LS22972E	6.27	5LS32912CW	6.33	5LS41271P	6.36	5LS44003	6.43
5LS22972EF3004	6.61	5LS32912EW	6.33	5LS41271Q	6.37	5LS44101	6.41
5LS22972EF4004	6.61	5LS32961EP1	6.25	5LS41271R	6.36	5LS44102	6.41
5LS31301AD	6.41	5LS32962EP1	6.25	5LS41271X	6.36	5LS44200EK	6.42
5LS31301CD	6.41	5LS32971A	6.25	5LS41271Y	6.36	5LS44201CS	6.41
5LS31301ED	6.41	5LS32971AY	6.29	5LS41272A	6.38	5LS44201ES	6.41
5LS31301EK	6.11, 6.21, 6.32	5LS32971C	6.25	5LS41272B	6.37	5LS44201MS	6.41
5LS31302AD	6.41	5LS32971CF3	6.60	5LS41272C	6.38	5LS44201PS	6.41
5LS31302CD	6.41, 6.46, 6.51	5LS32971CF3005	6.60	5LS41272CA0007	6.38	5LS44201RS	6.41
5LS31302ED	6.41, 6.46, 6.51	5LS32971CF4	6.60	5LS41272E	6.38	5LS44202CS	6.41
5LS31311EK	6.11, 6.21, 6.32	5LS32971CF4005	6.60	5LS41272EA0007	6.38	5LS44202ES	6.41
5LS31321EK	6.11, 6.21, 6.32	5LS32971CP1	6.25	5LS41272EA04	6.40	5LS44202MS	6.41
5LS32000EW	6.12	5LS32971CT1	6.55	5LS41272EA05	6.40	5LS44202PS	6.41
5LS32171E	6.17	5LS32971CT55	6.57	5LS41272F	6.36	5LS44202RS	6.41
5LS32171EY	6.20	5LS32971CY	6.29	5LS41272JE	6.36	5LS44211EK	6.42
5LS32172E	6.17	5LS32971E	6.25	5LS41272L	6.37	5LS44301CS	6.41
5LS32172EY	6.20	5LS32971EA04	6.28	5LS41272M	6.36	5LS44301EK	6.42
5LS32200EK	6.11, 6.21, 6.32	5LS32971EA05	6.28	5LS41272P	6.36	5LS44301ES	6.41
5LS32200XV	6.11, 6.22, 6.32, 6.42	5LS32971EF3	6.60	5LS41272R	6.36	5LS44302CS	6.41
5LS32201AD	6.21, 6.31	5LS32971EF3005	6.60	5LS41272W	6.37	5LS44302ES	6.41
5LS32201AW	6.22	5LS32971EF4	6.60	5LS41272Y	6.36	5LS44311EK	6.42
5LS32201CD	6.21, 6.31	5LS32971EF4005	6.60	5LS412D1E	6.38	5LS44321EK	6.42
5LS32201CS	6.21, 6.31	5LS32971EP1	6.25	5LS412D1J	6.36	5LS44901AW	6.43
5LS32201CST1	6.31	5LS32971ES4	6.26	5LS412D1X	6.36	5LS44901CW	6.43
5LS32201CW	6.22	5LS32971ET1	6.55	5LS412D2E	6.38	5LS44901EW	6.43
5LS32201ED	6.21, 6.31	5LS32971ET55	6.57	5LS41771A	6.39	5LS44902AW	6.43
5LS32201ES	6.21, 6.31	5LS32971EY	6.29	5LS41771C	6.39	5LS44902CW	6.43
5LS32201EST1	6.31	5LS32972C	6.25	5LS41771E	6.39	5LS44902EW	6.43
5LS32201EW	6.22	5LS32972CF3	6.60	5LS41771EA0004	6.39	5LS44911AW	6.43
5LS32202CD	6.21, 6.31	5LS32972CF3005	6.60	5LS41772C	6.39	5LS44911CW	6.43
5LS32202CS	6.21, 6.31	5LS32972CF4	6.60	5LS41772E	6.39	5LS44911EW	6.43
5LS32202CW	6.22	5LS32972CF4005	6.60	5LS41772EA0004	6.39	5LS44912AW	6.43
5LS32202ED	6.21, 6.31	5LS32972CP1	6.25	5LS42261C	6.38	5LS44912CW	6.43
5LS32202ES	6.21, 6.31	5LS32972CT1	6.55	5LS42261E	6.38	5LS44912EW	6.43
5LS32202EW	6.22	5LS32972CY	6.29	5LS42261J	6.36	5LS90800ED	5.70, 5.82
5LS32211EK	6.11, 6.21, 6.32	5LS32972E	6.25	5LS42262E	6.38	5LS90800XD	6.64
5LS32261E	6.16	5LS32972EA04	6.28	5LS42271A	6.38	5LS90871E	5.81
5LS32262E	6.16	5LS32972EA05	6.28	5LS42271B	6.37	5LS90871EF0	5.82
5LS32271A	6.16	5LS32972EF3	6.60	5LS42271C	6.38	5LS90872E	5.81
5LS32271C	6.16	5LS32972EF3005	6.60	5LS42271CC05	6.40	5LS90872EF0	5.82
5LS32271E	6.16	5LS32972EF4	6.60	5LS42271E	6.38	5LS90900XC1	6.12, 6.22, 6.33, 6.65
5LS32271EA04	6.18	5LS32972EF4005	6.60	5LS42271EC05	6.40	5LS90900XC2	6.47, 6.52, 6.66
5LS32271EY	6.19	5LS32972EP1	6.25	5LS42271F	6.36	5LS90900XD	5.79, 6.64
5LS32272C	6.16	5LS32972ES4	6.26	5LS42271H	6.37	5LS90910XD	5.79, 6.64
5LS32272CY	6.19	5LS32972ET1	6.55	5LS42271J	6.36	5LS90920E	6.63
5LS32272E	6.16	5LS32972EY	6.29	5LS42271L	6.37	5LS90930E	6.63
5LS32272EA04	6.18	5LS329B1CT6	6.57	5LS42271M	6.36	5LS91011EN	6.63
5LS322D1E	6.16	5LS329B1CT7	6.57	5LS42271P	6.36	5LS91012EN	6.63
5LS322D2E	6.16	5LS329B1ET1	6.55	5LS42271Q	6.37	5LS91013EN	6.63
5LS32361E	6.17	5LS329B1ET6	6.57	5LS42271R	6.36	5LS91101	6.67
5LS32362E	6.17	5LS329B1ET7	6.57	5LS42271X	6.36	5LS91101EA	5.34, 6.67
5LS32371E	6.17	5LS329B2CT6	6.57	5LS42271Y	6.36	5LS91101EV	6.67
5LS32371EY	6.20	5LS329B2ET1	6.55	5LS42272A	6.38	5LS91102	6.67
5LS32372E	6.17	5LS329B2ET6	6.57	5LS42272B	6.37	5LS91103	6.67

Order No.	Page	Order No.	Page	Order No.	Page	Order No.	Page
5LS91106	6.67	5MC12674MW	2.115	5MC25462QS1	2.23	5MF21471LS	2.72
5LS91120EC	6.12, 6.22, 6.33, 6.43, 6.67	5MC12674YS	2.115	5MC25462QS2	2.22	5MF21471QS	2.72
5LS96800ED	5.70	5MC12674YW	2.115	5MC25472HS1	2.23	5MF21B71HS	2.71
5LY11103R	Appendix/21	5MC126D1FS	2.114	5MC25472HS2	2.22	5MF21B71LS	2.71
5LY11104R	Appendix/21	5MC126D1FW	2.114	5MC25472QS1	2.23	5MF21B71QS	2.71
5LY11105R	Appendix/21	5MC126D1JS	2.114	5MC25472QS2	2.22	5MF21P71HS	2.73
5LY3081	6.50	5MC126D1JW	2.114	5MC254D2HS1	2.23	5MF21P71LS	2.73
5LY5002	3.134, Appendix/19	5MC126D2PS	2.114	5MC254D2HS2	2.22	5MF21P71QS	2.73
5LY5003	Appendix/19	5MC126D2PW	2.114	5MC254D2QS1	2.23	5MF21W71HS	2.74
5LY5005	Appendix/19	5MC126D2RS	2.114	5MC254D2QS2	2.22	5MF21W71QS	2.74
5LY5007	Appendix/19	5MC126D2RW	2.114	5MC62671FS	2.118	5MF23471HS	2.35
5LY5008	Appendix/19	5MC12B71FS	2.112	5MC62671FW	2.118	5MF23471LS	2.35
5LY5013	Appendix/19	5MC12B71FW	2.112	5MC62671JS	2.118	5MF23471QS	2.35
5LY5014	Appendix/19	5MC12B71JS	2.112	5MC62671JW	2.118	5MF23475HS	2.35
5LY5015	Appendix/19	5MC12B71JW	2.112	5MC62671XS	2.118	5MF23475LS	2.35
5LY5016	3.134, Appendix/19	5MC12B71XS	2.112	5MC62671XW	2.118	5MF23475WS	2.35
5LY5018	3.134, Appendix/19	5MC12B71XW	2.112	5MC62671YS	2.118	5MF23871HS	2.33
5LY5020	3.134, Appendix/19	5MC12B71YS	2.112	5MC62671YW	2.118	5MF23871QS	2.33
5LY5028	Appendix/19	5MC12B71YW	2.112	5MC62672FS	2.118	5MF23B65HS	2.34
5LY9001	2.96, 3.35, 5.35, 5.106, 6.42	5MC12B72MS	2.112	5MC62672FW	2.118	5MF23B65WS	2.34
5LY9002	2.96, 3.35, 5.35, 5.106, 6.42	5MC12B72MW	2.112	5MC62672JS	2.118	5MF23B71HS	2.34
5LY9003	2.96, 3.35, 5.35, 5.106, 6.42	5MC12B72PS	2.112	5MC62672JW	2.118	5MF23B71LS	2.34
5LY9004	2.96, 3.35, 5.35, 5.106, 6.42	5MC12B72PW	2.112	5MC62672MS	2.118	5MF23B71QS	2.34
5LY90554.9, 5.43, 5.72, 5.87, 6.12, 6.22, 6.33, 6.47, 6.52, 6.65, 7.10, 7.21, 7.25		5MC12B72RS	2.112	5MC62672MW	2.118	5MF23B75HS	2.34
5LY9084	6.11, 6.22, 6.33	5MC12B72RW	2.112	5MC62672PS	2.118	5MF23B75LS	2.34
5LY9086	4.9, 6.11, 6.22, 6.33, 6.47, 6.51	5MC12B74MS	2.113	5MC62672PW	2.118	5MF23B75WS	2.34
5LY90860	6.11, 6.22, 6.33, 6.47, 6.51	5MC12B74MW	2.113	5MC62672RS	2.118	5MF23P71HS	2.36
5LY908616.11, 6.22, 6.33, 6.47, 6.51, 6.67		5MC12BD1FW	2.112	5MC62672RW	2.118	5MF23P71LS	2.36
5LY91105	2.28	5MC12BD1JW	2.112	5MC62672XS	2.118	5MF23P71QS	2.36
5LY91106	2.28	5MC12BD2PS	2.112	5MC62672XW	2.118	5MF23W71HS	2.37
5LY91107	2.28	5MC12BD2PW	2.112	5MC62672YS	2.118	5MF23W71QS	2.37
5LY91108	2.28	5MC12BD2RS	2.112	5MC62672YW	2.118	5MF41471HS	2.72
5LY91116.12, 6.22, 6.33, 6.47, 6.52, 6.67		5MC12BD2RW	2.112	5MC62674MS	2.119	5MF41471WS	2.72
5LY91115	2.28	5MC12BD4MS	2.113	5MC62674MW	2.119	5MF41B71HS	2.71
5LY91116	2.28	5MC12BD4MW	2.113	5MC62674YS	2.119	5MF41B71WS	2.71
5LY91135.43, 5.72, 5.87, 6.12, 6.22, 6.33, 6.47, 6.52, 6.65, 7.10, 7.21, 7.25		5MC22671FS	2.68	5MC62674YW	2.119	5MF41P71HS	2.73
5LY9114	4.9	5MC22671JS	2.68	5MC62678US	2.119	5MF41P71WS	2.73
5LY91152.50, 2.85, 2.91, 2.149, 2.151, 2.155, 7.10		5MC22671US	2.68	5MC62678UW	2.119	5MF41W71HS	2.74
5LY91162.50, 2.85, 2.91, 2.149, 2.151, 2.155, 7.10		5MC22671XS	2.68	5MC626D1FS	2.118	5MF41W71WS	2.74
5LY91172.50, 2.85, 2.91, 2.149, 2.151, 2.155, 7.10		5MC22671YS	2.68	5MC626D1FW	2.118	5MF43471HS	2.35
5LY91182.50, 2.85, 2.91, 2.149, 2.151, 2.155, 7.10		5MC22672FS	2.68	5MC626D1JS	2.118	5MF43471WS	2.35
5LY91201	2.86	5MC22672JS	2.68	5MC626D1JW	2.118	5MF43475HS	2.35
5LY91202	2.86	5MC22672MS	2.68	5MC626D2PS	2.118	5MF43475WS	2.35
5LY91203	2.86	5MC22672RS	2.68	5MC626D2PW	2.118	5MF43871HS	2.33
5LY9140	4.9	5MC22672RW	2.68	5MC626D2RS	2.118	5MF43871WS	2.33
5LY91401	7.10	5MC22672XS	2.68	5MC626D2RW	2.118	5MF43B71HS	2.34
5LY9141	4.9	5MC22672YS	2.68	5MC626D2RS	2.116	5MF43B71WS	2.34
5LY9142	2.85, 4.9, 6.65	5MC22674MS	2.69	5MC62B71FS	2.116	5MF43B75HS	2.34
5LY91802.149, 2.151, 2.155, 6.11, 6.21, 6.32		5MC22674YS	2.69	5MC62B71JW	2.116	5MF43B75WS	2.34
5LY9183	2.50, 7.10	5MC22676YS	2.69	5MC62B71XS	2.116	5MF43P71HS	2.36
5MC12671FS	2.114	5MC22678US	2.69	5MC62B71XW	2.116	5MF43P71WS	2.36
5MC12671FW	2.114	5MC226D1FS	2.68	5MC62B71YS	2.116	5MF43W71HS	2.37
5MC12671JS	2.114	5MC226D1JW	2.68	5MC62B71YW	2.116	5MF90001	2.37, 2.74
5MC12671JW	2.114	5MC226D1JS	2.68	5MC62B72MS	2.116	5MG12673M	2.140
5MC12671XS	2.114	5MC226D2FS	2.68	5MC62B72MS	2.116	5MG12674M	2.140
5MC12671XW	2.114	5MC226D2JS	2.68	5MC62B72MW	2.116	5MG12674M	2.140
5MC12671YS	2.114	5MC226D2MS	2.68	5MC62B72PS	2.116	5MG12B73M	2.139
5MC12671YW	2.114	5MC226D2PS	2.68	5MC62B72PW	2.116	5MG12B74M	2.139
5MC12672FS	2.114	5MC226D2RS	2.68	5MC62B72RW	2.116	5MJ20001	2.85
5MC12672FW	2.114	5MC22B71FS	2.66	5MC62B72RS	2.116	5MJ20002	2.86
5MC12672JS	2.114	5MC22B71JS	2.66	5MC62B72RW	2.117	5MJ20002BS	2.85
5MC12672JW	2.114	5MC22B71JW	2.66	5MC62B74MS	2.117	5MJ20002HA	2.85
5MC12672MS	2.114	5MC22B71XS	2.66	5MC62B74MW	2.117	5MJ20002HS	2.85
5MC12672MW	2.114	5MC22B71YS	2.66	5MC62BD1FW	2.116	5MJ20002QA	2.85
5MC12672PS	2.114	5MC22B72MS	2.66	5MC62BD1JW	2.116	5MJ20002QS	2.85
5MC12672PW	2.114	5MC22B72PS	2.66	5MC62BD2PS	2.116	5MJ20004BS	2.85
5MC12672RS	2.114	5MC22B72RS	2.66	5MC62BD2PW	2.116	5MJ20004BW	2.85
5MC12672RW	2.114	5MC22B72RW	2.67	5MC62BD2RS	2.116	5MJ20005BS	2.85
5MC12672XS	2.114	5MC22B74MS	2.67	5MC62BD2RW	2.116	5MJ20005BW	2.85
5MC12672XW	2.114	5MC22B76YS	2.67	5MC62BD4MW	2.117	5MJ21102BW	2.87
5MC12672YS	2.114	5MC22BD1FS	2.66	5MC90001	2.120	5MJ21102HW	2.87
5MC12672YW	2.114	5MC22BD1JS	2.66	5MC90101	2.120	5MJ21102QW	2.87
5MC12674MS	2.115	5MC22BD2PS	2.66	5MC90102	2.120	5MJ21161Q	2.81
		5MC22BD2RS	2.66	5MC90201	2.27, 2.69	5MJ21162B	2.81
		5MC24B71JS	2.25	5MC90202	2.27, 2.69	5MJ21162H	2.81
		5MC24B71XS	2.25	5MC90601	2.120	5MJ21162Q	2.81
		5MC24B72FS	2.25	5MC90602	2.120	5MJ21171B	2.81
		5MC24B72JS	2.25	5MC91001	2.27	5MJ21171H	2.81
		5MC24BD1JS	2.25	5MC91002	2.27	5MJ21171Q	2.81
		5MC24BD2FS	2.25	5MC91003	2.27	5MJ21172B	2.81
		5MC24BD2JS	2.25	5MC91004	2.27	5MJ21172H	2.81
		5MC25462HS1	2.23	5MF21471HS	2.72		
		5MC25462HS2	2.22				

Order No.	Page	Order No.	Page	Order No.	Page	Order No.	Page
5MJ21172Q	2.81	5NA52004XS	9.54	5NA758E1SB0208	7.33	5NJ36131ENL	7.24
5MJ211D1Q	2.81	5NA52005XS	9.54	5NA758E1SB21	7.35	5NJ36131FNL	7.24
5MJ211D2B	2.81	5NA52005XS1	9.54	5NA758E1SB22	7.35	5NJ36231ENL	7.23
5MJ211D2H	2.81	5NA52800BF	9.54	5NA758E1SS0108	7.33	5NJ36231FNL	7.23
5MJ211D2Q	2.81	5NA52821AS28	9.49	5NA758E1SS0208	7.33	5NJ60031AN	7.17
5MJ22202BW	2.87	5NA52821AS38	9.49	5NA758E1SS21	7.35	5NJ60031DN	7.13, 7.15, 7.16
5MJ22202HW	2.87	5NA52821AS58	9.50	5NA758E1SS22	7.35	5NJ60031EN	7.13, 7.14, 7.15, 7.16
5MJ22202QW	2.87	5NA52821AS68	9.50	5NA758E1TB0108	7.33	5NJ60031EN03	7.20
5MJ22261B	2.82	5NA528E1AR28	9.49	5NA758E1TB0208	7.33	5NJ60031ENT	7.19
5MJ22261H	2.82	5NA528E1AR38	9.49	5NA758E1TB21	7.35	5NJ60031FN	7.15, 7.16
5MJ22261Q	2.82	5NA528E1AR58	9.50	5NA758E1TB22	7.35	5NJ60031FN03	7.20
5MJ22262B	2.82	5NA528E1AR68	9.50	5NA758E1TS0108	7.33	5NJ60031FNA	7.13, 7.14
5MJ22262H	2.82	5NA528E1MR28	9.49	5NA758E1TS0208	7.33	5NJ60031FNT	7.19
5MJ22262Q	2.82	5NA528E1MR38	9.49	5NA758E1TS21	7.35	5NJ60031TN	7.17
5MJ22271B	2.82	5NA528E1MR58	9.50	5NA758E1TS22	7.35	5NJ60031XN	7.13, 7.14, 7.15, 7.16
5MJ22271H	2.82	5NA528E1MR68	9.50	5NA75921VK0	8.23	5NJ60031XN03	7.20
5MJ22271Q	2.82	5NA528E1MS28	9.49	5NA75921VR0	7.17, 7.21, 8.23	5NJ60031XNT	7.19
5MJ22272B	2.82	5NA528E1MS38	9.49	5NA75921VR11	7.17, 7.21	5NJ60031YN	7.15, 7.16
5MJ22272H	2.82	5NA528E1MS58	9.50	5NA77921VR0	8.23	5NJ60031YN03	7.20
5MJ22272Q	2.82	5NA528E1MS68	9.50	5NA9000R	9.39	5NJ60031YNT	7.19
5MJ222D1B	2.82	5NA52921AS28	9.51	5NA90011B100R	9.37	5NJ60071WN	7.13, 7.15, 7.16
5MJ222D1H	2.82	5NA52921AS28D	9.53	5NA90011LE100R	9.37	5NJ60073MN	7.13, 7.15, 7.16
5MJ222D1Q	2.82	5NA52921AS38	9.51	5NA90011LS100R	9.37	5NJ63731KNH	7.18
5MJ222D2Q	2.82	5NA52921AS58	9.52	5NA90011MB100R	9.37	5NJ63731LNH	7.18
5MJ22302BW	2.87	5NA52921AS68	9.52	5NA90011ME100R	9.37	5NJ84401XC	3.34
5MJ22302HW	2.87	5NA52921CS28	9.51	5NA90011MS100R	9.37	5NJ84401XD	3.34
5MJ22302QW	2.87	5NA52921CS28D	9.53	5NA90011PB100R	9.37	5NJ90000A	3.35
5MJ22361HS	2.80	5NA52921CS38	9.51	5NA90011PE100R	9.37	5NW13991QA	8.10
5MJ22361QS	2.80	5NA52921CS58	9.52	5NA90011PS100R	9.37	5NW13991QB	8.10
5MJ22362BS	2.80	5NA52921CS68	9.52	5NA95011NA100	9.38	5NW13991QC	8.10
5MJ22362QS	2.80	5NA529E1AR28	9.51	5NA95011NS100	9.38	5NW13993QA	8.10
5MJ22371BS	2.80	5NA529E1AR28D	9.53	5NA95011PA100	9.38	5NW13993QB	8.10
5MJ22371HS	2.80	5NA529E1AR38	9.51	5NA95011PS100	9.38	5NW13993QC	8.10
5MJ22371QS	2.80	5NA529E1AR58	9.52	5NG15502QM1	3.71	5NW14091QA	8.11
5MJ22372BS	2.80	5NA529E1AR68	9.52	5NG15503QM1	3.71	5NW14091QB	8.11
5MJ22372HS	2.80	5NA529E1CR28	9.51	5NG15505KM1	3.72	5NW14091QC	8.11
5MJ22372QS	2.80	5NA529E1CR28D	9.53	5NG15602QM1	3.73	5NW14093QA	8.11
5MJ223D1QS	2.80	5NA529E1CR38	9.51	5NG15603QM1	3.73	5NW14093QB	8.11
5MJ223D2BS	2.80	5NA529E1CR58	9.52	5NG15605KM1	3.74	5NW14093QC	8.11
5MJ223D2QS	2.80	5NA529E1CR68	9.52	5NG16076L	3.75, 3.91, 3.133	5NW41221MG1	8.16
5MJ23102HW	2.87	5NA529E1MR28	9.51	5NG16077L	3.75, 3.91, 3.133	5NW41221PG1	8.16
5MJ23102QW	2.87	5NA529E1MR28D	9.53	5NG16078L	3.75, 3.133	5NW41271MG1	8.16
5MJ23161Q	2.84	5NA529E1MR38	9.51	5NJ14301XC	7.21	5NW41271PG1	8.16
5MJ23162H	2.84	5NA529E1MR58	9.52	5NJ14301XD	7.21	5NW41421RG1	8.17
5MJ23162Q	2.84	5NA529E1MR68	9.52	5NJ200000	3.34	5NW41421TG1	8.17
5MJ23171H	2.84	5NA529E1MS28	9.51	5NJ20031BP	3.28, 3.30, 3.32	5NW72640QA	8.13
5MJ23171Q	2.84	5NA529E1MS28D	9.53	5NJ20031CP	3.28, 3.30, 3.32	5NW72640QB	8.13
5MJ23172H	2.84	5NA529E1MS38	9.51	5NJ20031WP	3.28, 3.30, 3.32	5NW72640QC	8.13
5MJ23172Q	2.84	5NA529E1MS58	9.52	5NJ20071HP	3.30, 3.32	5NW72640QD	8.13
5MJ24302HW	2.87	5NA529E1MS68	9.52	5NJ20071PP	3.29, 3.31, 3.33	5NW92640A	8.13
5MJ24302QW	2.87	5NA59000XF	7.21	5NJ20071SP	3.28, 3.30, 3.32	5NW92640B	8.13
5MJ24361QS	2.83	5NA74921VE0	8.23	5NJ20071VP	3.29, 3.31, 3.33	5NW92640C	8.13
5MJ24362HS	2.83	5NA75601VP11C	8.23	5NJ211000	3.28, 3.29	5NX72200XGS1	9.30
5MJ24362QS	2.83	5NA75671WP11C	8.23	5NJ211000000A	3.28, 3.29	5NX72200XGS2	9.30
5MJ24371HS	2.83	5NA75701SS0208H	7.32	5NJ211000000B	3.28, 3.29	5NX72200XGS3	9.30
5MJ24371QS	2.83	5NA75701SS2208H	7.34	5NJ211000000C	3.28, 3.29	5NX722E1HB08	9.26
5MJ24372HS	2.83	5NA75761NS0208	7.32	5NJ211000000D	3.28, 3.29	5NX722E1HB11	9.27
5MJ24372QS	2.83	5NA75761PS0208	7.32	5NJ211000000E	3.28, 3.29	5NX722E1HS08	9.26
5MM12465UX	2.39	5NA75771NS0208	7.32	5NJ211000000F	3.28, 3.29	5NX722E1HS11	9.27
5MM12466YX	2.39	5NA75771NS2208	7.34	5NJ221000	3.28, 3.29	5NX722E1MB08	9.26
5MM12467TJ	2.39	5NA757E1NS0108	7.32	5NJ234000	3.30, 3.31	5NX722E1MB11	9.27
5MM12475UX	2.39	5NA757E1NS0208	7.32	5NJ235000	3.32, 3.33	5NX722E1MS08	9.26
5MM12476YX	2.39	5NA757E1NS2108	7.34	5NJ300000	7.21	5NX722E1MS11	9.27
5MM12477TJ	2.39	5NA757E1NS2208	7.34	5NJ30000T	7.21	5NX72400XB01	8.20, 9.30
5MS42663UL0D	1.5	5NA757E1PS0208	7.32	5NJ30000XB	7.21	5NX72400XG0208	9.30
5MS42664UL0D	1.5	5NA757E1PS2208	7.34	5NJ30031TM	7.17, 7.21	5NX72400XG0308	9.30
5MS42672UK0	1.6	5NA75801VB0208H	7.33	5NJ311000	7.13, 7.19, 7.20	5NX72400XG0408	9.30
5MS42673UL0	1.3	5NA75801VS0208H	7.33	5NJ316000	7.14	5NX72400XG18	9.30
5MS42673US0	1.4	5NA75861SB0208	7.33	5NJ331000	7.15, 7.17, 7.19, 7.20	5NX72400XG4208	9.30
5MS42674UL0	1.3	5NA75861SS0208	7.33	5NJ332000	7.15, 7.17, 7.19, 7.20	5NX72400XGD2	9.30
5MS42677VK0	1.6	5NA75861TB0208	7.33	5NJ333000	7.16, 7.19, 7.20	5NX72400XGD3	9.30
5MS42678VL0	1.3	5NA75861TS0208	7.33	5NJ337000	7.21	5NX72400XGD4	9.30
5MS42679VL0	1.3	5NA75871RB0208	7.33	5NJ340000	7.25	5NX72400XGD5	9.30
5MS43672UL0	4.3	5NA75871RS0208	7.33	5NJ35131EN	7.24	5NX72400XGD6	9.30
5MS43677VL0	4.3	5NA75871TB0208	7.33	5NJ35131FN	7.24	5NX72400XGS1	9.30
5NA29100BF	9.47	5NA75871TS0208	7.33	5NJ35131XN	7.24	5NX72400XGS2	9.30
5NA291E1MA08	9.47	5NA758E1RB0208	7.33	5NJ35131YN	7.24	5NX724E1MB08	8.20, 9.29
5NA291E1MS08	9.47	5NA758E1RB22	7.35	5NJ35231EN	7.23	5NX724E1MS08	9.29
5NA52000XS	9.54	5NA758E1RS0208	7.33	5NJ35231FN	7.23	5NX724E1PB08	8.20, 9.29
5NA52002XS	9.54	5NA758E1RS22	7.35	5NJ35231XN	7.23	5NX724E1PS08	9.29
5NA52003XS	9.54	5NA758E1SB0108	7.33	5NJ35231YN	7.23	5NX725E1MB11	8.21, 9.28

Order No.	Page	Order No.	Page	Order No.	Page	Order No.	Page
5NX725E1MG11	8.21, 9.28	5TR16250Q	5.8	5TR36161H	5.10	5TR56140Q	5.24
5NX725E1PB11	8.21, 9.28	5TR162A0H	5.8	5TR36161Q	5.10	5TR56290H	5.19
5NX725E1PG11	8.21, 9.28	5TR162A0Q	5.8	5TR36162H	5.10	5TR56290Q	5.19
5NX76121E	7.27	5TR16350H	5.8	5TR36162Q	5.10	5TR56490H	5.18
5NX76121F	7.27	5TR16350Q	5.8	5TR36171H	5.10	5TR56490Q	5.18
5NX76121N	7.27	5TR163A0H	5.8	5TR36171Q	5.10	5TR60120H	5.17
5NX76121V	7.27	5TR163A0Q	5.8	5TR36172H	5.10	5TR60120Q	5.17
5NX76620N	7.28	5TR16450H	5.8	5TR36172Q	5.10	5TR60150H	5.15
5NX76721E	7.28	5TR164A0H	5.8	5TR361D1H	5.10	5TR60150Q	5.15
5NX76721F	7.28	5TR30000H	5.33	5TR361D1Q	5.10	5TR60320H	5.16
5NX76721N	7.28	5TR30000Q	5.33	5TR361D2H	5.10	5TR60320Q	5.16
5NX76721V	7.28	5TR30161H	5.10	5TR361D2Q	5.10	5TR60350H	5.14
5NX76821E	7.29	5TR30161Q	5.10	5TR36200Q	5.33	5TR60350Q	5.14
5NX76821N	7.29	5TR30162H	5.10	5TR36361H	5.11	5TR76000Q	5.31
5NX90000XG00	9.39	5TR30162Q	5.10	5TR36361H1H	5.13	5TR76564X	5.29
5NX90000XG00R	9.39	5TR30171H	5.10	5TR36361Q	5.11	5TR76574X	5.29
5NX90000XG01	9.39	5TR30171Q	5.10	5TR36361Q1H	5.13	5TR76574X2	5.29
5NX90000XG02	9.39	5TR30172H	5.10	5TR36362H	5.11	5TR765D4X	5.29
5NX90000XG03	9.39	5TR30172Q	5.10	5TR36362H1H	5.13	5TR76664X	5.30
5NX90000XG04	9.39	5TR301D1H	5.10	5TR36362Q	5.11	5TR76674X	5.30
5NX90000XG42	9.39	5TR301D1Q	5.10	5TR36362Q1H	5.13	5TR76674X2	5.30
5NX95000XG00	9.39	5TR301D2H	5.10	5TR36371H	5.11	5TR766D4X	5.30
5NX95000XG00R	9.39	5TR301D2Q	5.10	5TR36371H1H	5.13	5TR901101	5.9
5NX95000XG01	9.39	5TR30200Q	5.33	5TR36371HR	5.12	5TR9012	5.35
5NX95000XG02	9.39	5TR30361H	5.11	5TR36371Q	5.11	5TR901302	5.35
5NX95000XG03	9.39	5TR30361H1H	5.13	5TR36371Q1H	5.13	5TR901312	5.35
5NX95000XG04	9.39	5TR30361Q	5.11	5TR36371QR	5.12	5TR901322	5.35
5NX95000XG42	9.39	5TR30361Q1H	5.13	5TR36372H	5.11	5TR901332	5.35
5NY70005XK	9.45	5TR30362H	5.11	5TR36372H1H	5.13	5TR90142	5.34
5NY72400XE10	9.31	5TR30362H1H	5.13	5TR36372HR	5.12	5TR9016	5.9
5NY72400XM18	9.31	5TR30362Q	5.11	5TR36372Q	5.11	5TR90171	5.9
5NY72400XR	9.31	5TR30362Q1H	5.13	5TR36372Q1H	5.13	5TR90172	5.9
5NY72400XS2	9.30	5TR30371H	5.11	5TR36372QR	5.12	5TR90173	5.9
5NY72400XW18	8.20, 8.21, 9.31	5TR30371H1H	5.13	5TR363D1H	5.11	5TR90540H	5.26
5NY72402XT10	9.31	5TR30371HR	5.12	5TR363D1H1H	5.13	5TR90540Q	5.26
5NY75701XW2108	7.34	5TR30371Q	5.11	5TR363D1HR	5.12	5TR90561	5.27
5NY75801XW21	7.35	5TR30371Q1H	5.13	5TR363D1Q	5.11	5TR90562	5.27
5NZ5084	3.75, 3.91, 3.133	5TR30371QR	5.12	5TR363D1Q1H	5.13	5TR90564	5.27
5PL10402B	3.13, 3.61	5TR30372H	5.11	5TR363D1QR	5.12	5TR905642	5.26
5PL10403B	3.13, 3.61	5TR30372H1H	5.13	5TR363D2H	5.11	5TR90579	5.26
5PL10552B	3.13, 3.61	5TR30372HR	5.12	5TR363D2H1H	5.13	5TR90580H	5.26
5PL10553B	3.13, 3.61	5TR30372Q	5.11	5TR363D2HR	5.12	5TR90580Q	5.26
5TR10150H	5.8	5TR30372Q1H	5.13	5TR363D2Q	5.11	5TR9066	5.26
5TR10150Q	5.8	5TR30372QR	5.12	5TR363D2Q1H	5.13	5TR9067	5.26
5TR101A0H	5.8	5TR303D1H	5.11	5TR363D2QR	5.12	5TR90675	5.26
5TR101A0Q	5.8	5TR303D1H1H	5.13	5TR36600	5.33	5TR90911	5.34
5TR10250H	5.8	5TR303D1HR	5.12	5TR36700B	5.33	5TR90912	5.34
5TR10250Q	5.8	5TR303D1Q	5.11	5TR36700H	5.33	5TR9092AH	5.9
5TR102A0H	5.8	5TR303D1Q1H	5.13	5TR50082H	5.27	5TR9092AQ	5.9
5TR102A0Q	5.8	5TR303D1QR	5.12	5TR50082Q	5.27	5TR90941	5.33
5TR10350H	5.8	5TR303D2H	5.11	5TR50120H	5.23	5TR90942	5.33
5TR10350Q	5.8	5TR303D2H1H	5.13	5TR50120Q	5.23	5TR961101	5.9
5TR103A0H	5.8	5TR303D2HR	5.12	5TR50140H	5.25	5TR961312	5.35
5TR103A0Q	5.8	5TR303D2Q	5.11	5TR50140Q	5.25	5TR961332	5.35
5TR10450H	5.8	5TR303D2Q1H	5.13	5TR56110H	5.21	5TR96171	5.9
5TR104A0H	5.8	5TR303D2QR	5.12	5TR56110Q	5.21	5TR96172	5.9
5TR16150H	5.8	5TR30600	5.33	5TR56120H	5.22	5TR96173	5.9
5TR16150Q	5.8	5TR30700B	5.33	5TR56120Q	5.22	5TR96912	5.34
5TR161A0H	5.8	5TR30700H	5.33	5TR56130H	5.20	5TR9692AH	5.9
5TR161A0Q	5.8	5TR36000H	5.33	5TR56130Q	5.20	5TR9692AQ	5.9
5TR16250H	5.8	5TR36000Q	5.33	5TR56140H	5.24		

1. Domestic Business

The 'General Delivery Conditions for Commodities and Services of the Electrical Industry' are valid as well as their appendice concerning Section III, Reservation of Proprietary Rights: 'Supplementary Provision: Extended Reservation of Proprietary Rights', and our 'General Sales Conditions', both in their latest stand.

If you are unfamiliar with these conditions, they may be obtained from us. These conditions are additionally available via our website: <http://www.siteco.com> (Service, Download, Sales and Order Conditions).

2. Export Business

The 'General Delivery Conditions for Commodities and Services of the Electrical Industry' are valid as well as all additional provisions agreed with the recipients of price lists.

3. Foreign Business

The latest stands of general delivery and sales conditions of each Siteco country subsidiary are valid as well as conditions disclosed in country-specific price lists, catalogues and brochures.

4. Miscellaneous/Taxes and Levies

Attention is drawn to the fact that value added tax is not included in prices. This is separately calculated according to the legal regulations of each specific country and according to each current rate. This is also the case for all further country-specific taxes and levies.

The contents of our catalogues are subject to international licence regulations. Publication of advertising therefore requires permission of our advertising partners.

All product designations used are trademarks, registered trademarks or product names of SITECO Beleuchtungstechnik GmbH or its partners.

Unless otherwise specified on the individual pages of this catalogue, we reserve the right to make changes without prior notice, particularly with regards to specified values, dimensions and weights.

Illustrations are not binding.

We reserve the right to adjust prices and will charge prices in force at time of delivery.

Luminaires are delivered without lamps unless otherwise specified.

Siteco Customer Service

Headquarters

Siteco Beleuchtungstechnik GmbH
Georg-Simon-Ohm-Straße 50
D-83301 Traunreut
Tel. +49 (0)8669 33-0
Fax +49 (0)8669 33-397
eMail: info@siteco.de
Internet: www.siteco.de

Queries concerning
product technology:
Tel. +49 (0)8669 33-844
Fax +49 (0)8669 86 53 29 44
eMail: technicalsupport@siteco.de

Queries concerning
calculation software:
Tel. +49 (0)8669 33-866
Fax +49 (0)8669 33-397
eMail: silicht@siteco.de

Siteco Sales Organisation

Sales Germany

Berlin
Nonnendammallee 42-43
13599 Berlin
Germany
Tel. +49 (0)30 - 35 53 09 10
Fax +49 (0)30 - 35 53 09 20
eMail: berlin@siteco.de

Frankfurt/Main
Solmsstraße 2
60486 Frankfurt/Main
Germany
Tel. +49 (0)69 - 97 09 74 10
Fax +49 (0)69 - 97 09 74 11
eMail: frankfurt-main@siteco.de

Hamburg
Valvo Park, Gebäude K
Essener Straße 4
22419 Hamburg
Germany
Tel. +49 (0)40 - 53 71 20 50
Fax +49 (0)40 - 53 71 20 77
eMail: hanse@siteco.de

Hannover
Dorfstraße 17
30519 Hannover
Germany
Tel. +49 (0)511 - 87 41 52 50
Fax +49 (0)511 - 87 41 52 40
eMail: hannover@siteco.de

Leipzig
Fugglerstraße 1A
04158 Leipzig
Germany
Tel. +49 (0)34 15 - 26 77 12
Fax +49 (0)34 15 - 26 77 20
eMail: leipzig@siteco.de

Lünen
An der Wethmarheide 34
44536 Lünen
Germany
Tel. +49 (0)23 06 - 20 04 0
Fax +49 (0)23 06 - 20 04 20
eMail: ruhr@siteco.de

Mannheim
Josef-Meyer-Straße 13-15
68167 Mannheim
Germany
Tel. +49 (0)621 - 3 97 01 0
Fax +49 (0)621 - 3 97 01 30
eMail: mannheim@siteco.de

Munich
Neumarkter Straße 80
81673 Munich
Germany
Tel. +49 (0)89 - 45 42 96 0
Fax +49 (0)89 - 45 42 96 77
eMail: muenchen@siteco.de

Nuremberg
Gebäude G/1. OG
Allersberger Straße 185
90461 Nuremberg
Germany
Tel. +49 (0)911 - 9 41 78 0
Fax +49 (0)911 - 9 41 78 31
eMail: nuernberg@siteco.de

Stuttgart
Rutesheimer Straße 24
70499 Stuttgart
Germany
Tel. +49 (0)711 - 88 02 37 0
Fax +49 (0)711 - 88 02 37 30
eMail: stuttgart@siteco.de

Sales Austria

Graz
Straßganger Straße 315
8054 Graz
Austria
Tel. +43 316 28 45 03
Fax +43 316 28 64 77
eMail: graz@siteco.at

Innsbruck
Tiergartenstraße 37
6023 Innsbruck
Austria
Tel. +43 512 39 43 43
Fax +43 512 39 43 45
eMail: innsbruck@siteco.at

Klagenfurt
Spitalbergweg 20
9020 Klagenfurt
Austria
Tel. +43 463 48 18 80
Fax +43 463 48 18 80 5
eMail: klagenfurt@siteco.at

Linz
Pillweinstraße 30
4020 Linz
Austria
Tel. +43 732 60 70 80
Fax +43 732 60 60 40
eMail: linz@siteco.at

Salzburg
Alte Aigner-Straße 41
5026 Salzburg
Austria
Tel. +43 662 62 58 02
Fax +43 662 62 58 02 22
eMail: salzburg@siteco.at

Vienna
Leonard-Bernstein-Straße 10
1220 Vienna
Austria
Tel. +43 1 250 24 0
Fax +43 1 250 24 255
eMail: wien@siteco.at

Sales Rest of Europe

Belgium
Cebeo NV
Oude Gentweg 100
2070 Zwijndrecht (Burcht)
Belgium
Tel. +32 3 250 51 11
eMail: info@cebeo.be

Bosnia and Herzegovina
Siteco Sistemi d.o.o
Ul. Hamdije Cemerica 2
71000 Sarajevo
Bosnia-Herzegovina
Tel. +387 33 71 86 40
Fax +387 33 65 48 14
eMail: bih@siteco.com

Croatia
Siteco Sistemi d.o.o.
Trg Drazena Petrovica 3
10000 Zagreb
Croatia
Tel. +385 1 481 24 17
Fax +385 1 484 35 88
eMail: croatia@siteco.com

Czech Republic
Siteco Lighting, spol. s r.o.
U Nikolajky 1085/15
15000 Prague 5-Smichov
Czech Republic
Tel. +420 25 10 13 800
Fax +420 25 15 60 772
eMail: info@siteco.cz

Denmark
Siteco Beleuchtungstechnik
Odinsvej 31
6500 Vejens
Denmark
Tel. +45 73 54 04 50
Fax +45 73 54 04 51
eMail: denmark@siteco.com

Finland (Interior Luminaires)
Pejan OY
Lemuntie 3-5
00510 Helsinki
Finland
Tel. +358 20 72 89 84 0
Fax +358 98 02 45 66
eMail: info@pejan.fi

Finland (Exterior Luminaires)
Silux Oy Ab
Ullapakatu 1
02320 Espoo
Finland
Tel. +358 98 02 20 77
Fax +358 98 02 18 90
eMail: info@silux.fi

France
SiDelux
56 bis rue du Vieux Colombier
51100 Reims
France
Tel. +33 3 26 61 72 29
Fax +33 3 26 61 80 19
eMail: sidelux@orange.fr

Greece
Siemens A.E.
Artemidos Center
P.O. Box 61011
15110 Amaroussio/ Athens
Greece
Tel. +30 21 06 86 45 78
Fax +30 21 06 86 45 62
eMail: info@siteco.de

Hungary
Siteco Lighting, spol sr.o.
U Nikolajky 1085/15
15000 Prague 5-Smichov
Czech Republic
Tel. +420 25 10 13 800
Fax +420 25 15 60 772
eMail: info@siteco.cz

Ireland
Siteco Ltd.
Unit 3-4 Grosvenor Business Park
Horsfield Way
Bredbury Industrial Estate
Stockport
SK6 2SU
United Kingdom
Tel. +44 1 61 40 60 800
Fax +44 1 61 49 46 756
eMail: info@siteco.co.uk

Italy
Siteco Lighting Systems S.r.l.
Via Gino Pollini 8
20125 Milano
Italy
Tel. +39 02 66 11 71 07
Fax +39 02 66 11 30 56
eMail: info@sitecoitalia.it

Latvia
Siteco Lighting Design Center
Riga
Ernesta Birznika-Upisa iela 18a
1050 Riga
Latvia
Tel. +371 67 36 59 12
Fax +371 67 36 59 11
eMail: janis@silicalatvija.lv

Lithuania
Sviesos Studija
Andrius Kleiza
Gelezinkelio str. 6
Vilnius 02100
Lithuania
Tel. +370 52 39 59 10
Fax +370 52 39 59 11
eMail: info@sviesos-studija.lt
www.sviesos-studija.lt

Luxembourg
Minusines S.A.
8, rue Hogenberg
1022 Luxembourg
Luxembourg
Tel. +352 49 58 58
Fax +352 49 58 66
eMail: info@minusines.lu

Netherlands (Interior Luminaires)
Industriëlight B.V.
Van Hennaertweg 7
2952 CA Alblasserdam
Netherlands
Tel. +31 78 69 20 900
Fax +31 78 69 20 905
eMail: info@industriëlight.nl

Norway
Siteco Belysning AS
Ole Deviks Vei 4
0666 Oslo
Norway
Tel. +47 23 37 32 50
Fax +47 23 37 32 60
eMail: info@siteco.no

Poland
Siteco Lighting Poland Sp.z.o.o
Migdalowa 4
02-796 Warszawa
Poland
Tel. +48 2 26 45 11 83
Fax +48 2 26 45 11 84
eMail: info@siteco.com.pl

Portugal
Siemens S.A.
A & D Iluminação
Rua Irmaõs Siemens 1
2720-093 Amadora
Portugal
Tel. +351 2 14 17 83 96
Fax +351 2 14 17 80 27
eMail: ilumina-cao.pt@siemens.com

Switzerland
Siteco Schweiz AG
Airport Business Center 62
3123 Belp-Bern
Switzerland
Tel. +41 3 18 18 28 28
Fax +41 3 18 18 28 20
eMail: info@siteco.ch

Serbia
Siteco Sistemi d.o.o.
Predstavništvo
Savnicka 11
11000 Beograd
Serbia
Tel. +381 11 123 99 509
Fax +381 11 123 99 509
eMail: serbia@siteco.com

Slovakia
Siteco Lighting, spol sr.o.
U Nikolajky 1085/15
15000 Prague 5-Smichov
Czech Republic
Tel. +420 251 013 800
Fax +420 251 560 772
eMail: info@siteco.cz

Slovenia
Siteco Sistemi d.o.o.
Trzaska c.23
2000 Maribor
Slovenia
Tel. +386 23 00 42 77
Fax +386 23 32 52 02
eMail: slovenia@siteco.com

Spain
Siemens S.A.
Division Productos y Sistemas
Industriales PST
Ronda de Europa, 5
28760 Tres Cantos (Madrid)
Spain
Tel. +34 9 15 14 70 50
Fax +34 9 15 14 70 16
eMail: info@siteco.de

Sweden
Annell Ljus + Form AB
Surbrunnsgratan 14
11421 Stockholm
Sweden
Tel. +46 8 442 90 00
Fax +46 8 442 90 25
eMail: info@annell.se

Turkey
Siteco Aydinlatma Tekniği
E5 Yanyol
Esentepe Mah. No:11
34870 Kartal / Istanbul
Turkey
Tel. +90 21 65 17 83 86
Fax +90 21 65 17 79 70
eMail: siteco@siteco.com.tr

England
Siteco Ltd
Unit 3-4 Grosvenor Business Park
Horsfield Way
Bredbury Industrial Estate
Stockport
SK6 2SU
United Kingdom
Tel. +44 16 14 06 08 00
Fax +44 16 14 94 67 56
eMail: info@siteco.co.uk

London:
Siteco Ltd
1-2 Hatfield Street
London SE1 9PJ
United Kingdom
Tel. +44 20 79 60 96 11
Fax +44 20 79 60 96 12
eMail: info@siteco.co.uk

Sales Worldwide

Headquarters China
Siteco Prosperity Lighting
(Hong Kong) Co., Ltd.
1401 Harbour Centre
25 Harbour Road, Wanchai
Hong Kong
China

Tel. +852 35 29 16 23
Fax +852 35 29 12 22
eMail: info@siteco-prosperity.com

Siteco Prosperity Lighting
(Langfang) Co., Ltd.
Beijing Branch Office
Room B2903 Eagle Plaza
No. 26 Xiao Yun Road
Chao Yang District
100016 Beijing
China
Tel. +86 10 84 58 01 19
Fax +86 10 84 58 02 98
eMail: beijing.info@siteco-prosperity.cn

Siteco Prosperity Lighting (Langfang)
Co., Ltd.
QuanXing Rd, Langfang Economic &
Technical Development Zone,
Hebei Province
Post code: 065001
China
Tel. +86 31 66 08 33 22
Fax +86 31 66 08 64 05

Siteco Prosperity Lighting
(Langfang) Co., Ltd.
Shanghai Branch Office
Room 404H
No. 179 Zhongshan Road (W)
200051 Shanghai
China
Fon +86 21 52 72 40 52
Fax +86 21 52 72 37 33
eMail: shanghai.info@siteco-
prosperity.com

Headquarters Middle East
Siteco Lighting Systems
Branch Office
DAFZA, Eastwing II, Office 308
P.O. Box 54317
Dubai
United Arab Emirates
Tel. +971 42 99 69 51
Fax +971 42 99 69 52
eMail: g.scott@siteco.com

Qatar
Debbas Qatar LLC
C-ring Road
P.O. Box 9791
Doha
Qatar
Tel. +974 4 67 89 31
Fax +974 4 67 86 91
eMail: info@debbasqatar.com

Egypt
El Sewedy Electrical
Equipment & Cables Co.
14 Saray El Azbakia St.
Cairo,
Egypt
P.O. Box 1604
Tel. +202 5 91 15 45
Fax +202 5 91 87 61
eMail: elsewedy@link.net

Kuwait
Siteco Lighting Design Center
Kuwait
Dajeej at Farwaniyah
Waha Mall
Shops 33 & 34
P.O. Box 5715 Salmiah
220068 Kuwait
Kuwait
Tel. +965 4 34 84 42
Fax +965 4 34 83 66
eMail: info@debbaskuwait.com

United Arab Emirates
ARASCA
(Arabic Scandinavian Gen. Trdg. Co.)
PO BOX 86637
Dubai
United Arab Emirates
Tel. +971 42 86 13 62
Fax +971 43 39 13 35
eMail: arasca@emirates.net.ae

Headquarters South East Asia Pacific
Siteco Lighting (M) Sdn Bhd
No 3A-15, IOI Business Park,
Bandar Puchong Jaya
47100 Puchong
Malaysia
Selangor Darul Ehsan
Tel. +603 80 70 47 22
Fax +603 80 70 88 45
eMail: info@siteco.com.my

Australia
Sylvania Lighting
Australasia Pty. Ltd.
Sylvania Way, Lisarow
2250 NSW
Australia
Tel. +61 2 43 28 06 00
Fax +61 2 43 28 06 98
eMail: sylvania@sla.net.au

Bangladesh
Siemens Bangladesh Limited
ZN Tower (Siemens House),
Plot-2, Road-8,
Gulshan Avenue, Gulshan-1,
Dhaka-1212
Bangladesh
Tel. +88 29 89 35 36
Fax +88 29 89 29 18
eMail: hr.bd@siemens.com

Indonesia
PT Sielitec
Cahaya Tunggal Indonesia
Kompleks Ferry Sonnevile
Block IV Kavling D1/D2
Gunung Putri
16961 Bogor
Indonesia
Tel. +62 21 8 67 14 67
Tel. +62 21 8 67 17 43
eMail: sielitec@indo.net.id

Korea
Siteco Lighting Design Center Seoul
1420 Rosedale Building
Soosoo-Dong Kangnam-Gu
135744 Seoul
South Korea
Tel. +82 2 62 42 10 98
Fax +82 2 62 42 11 97
eMail: mail@sitecokorea.co.kr

Singapore
Sielitec Pte. Ltd.
Singapore
49, Jalan Pemimpin # 03-05
APS Industrial Building
577203 Singapore
Singapore
Tel. +65 62 55 23 25
Fax +65 62 55 18 90
eMail: sielitec@singnet.com.sg

Sri Lanka
Diesel & Motor Engineering Co. Ltd.
65, Jethawana Road
Colombo - 14
Sri Lanka
Tel. +94 1 12 44 97 97
Fax +94 1 14 60 74 90
eMail: damith.meeghage@dimolanka.com

Taiwan
Lancaster Co. Ltd.
No. 323, Sung Shan Road
Taipei
Taiwan
Tel. +88 6 2 27 64 95 16
Fax +88 6 2 27 65 47 25
eMail: lancast2@ms4.hinet.net

Headquarters CIS/Russia
Siteco Lighting Systems
Krasnoproletarskaya str. 7
Building 2
127006 Moscow
Russia
Tel. +7 49 57 92 53 75
Fax +7 49 57 92 53 02
eMail: o.tarasenko@siteco.ru

Belorussia
Veche Svetotechnika
ul. Sovetskikh Progranitschnikov, 114
1230027 Grodno
Belorussia
Tel. +375 1 52 53 00 08
eMail: grodno@veche.by
Veche Svetotechnika
ul. Rosi Luxemburg, 95
220036 Minsk
Belorussia
Tel. +375 1 72 70 90 12
Fax +375 1 72 70 41 18
eMail: minsk@veche.by

South Africa
Lighting Innovations LTD.
Corner 5th Street & Carey Road
Wynberg, Sandton
P.O. Box 548
Bergvlei 2012
Johannesburg
South Africa
Tel. +27 11 44 44 11 68
Fax +27 11 44 41 16
eMail: craig@lightinginnovations.co.za

Venezuela
Dierck Sistemas de Iluminacion
4ta Avenida y 5ta Transversal
Quinta Mandalay
Los Palos Grandes
1060 Caracas
Venezuela
Tel. +58 21 22 87 08 64
Fax +58 21 22 87 07 43
eMail: info@dierck.vc