

AXIALLY SYMMETRICAL COMPACT PROJECTOR ACHSEN SYMMETRISCHER KOMPAKTPROJEKTOR

5 NX 722

IP 65 

230V~ / 240V~, 50Hz (220V~, 60Hz)

1. Identification and overall dimensions

Identifikation und Hauptabmessungen

All dimensions in (mm) / Alle Maße in (mm)

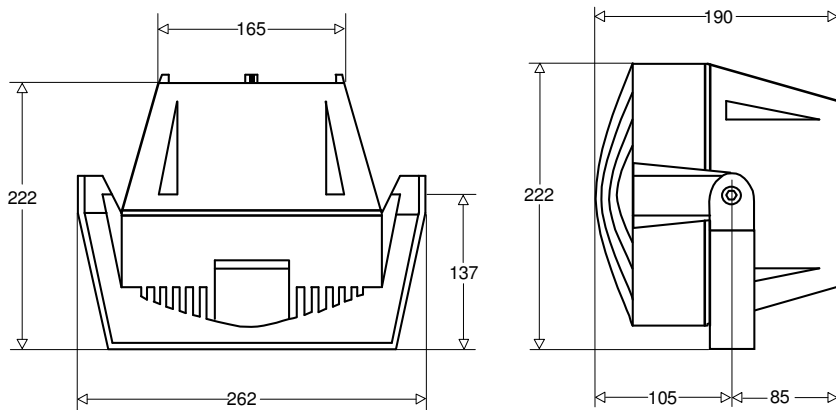

1.1 Mounting

Befestigung

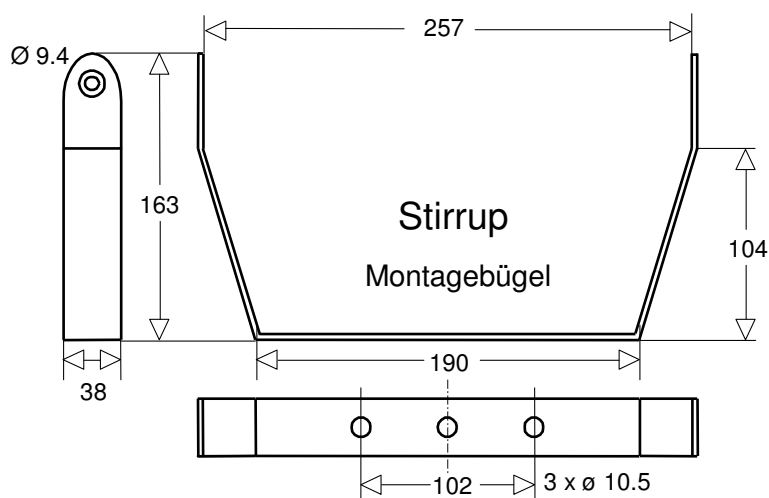

Operating range Schwenkbereich	360° for 35W and 70W 270° for 150W
Windage area Windangriffsfläche	Aw = 0.03m² (front / von vorne) Aw = 0.04m² (side / seitlich)
Ambient temperature Umgebungstemperatur	ta max. 25°C (indoor / innen) ta max. 35°C (outdoor / außen)
Mounting height Montagehöhe	As required / beliebig

1.2 Weights

Gewichte

5 NX 722 E-1HB0*	1xCRI 35W	4.6 kg
5 NX 722 E-1HS0*	1xCRI 35W	4.6 kg
5 NX 722 E-1MB0*	1xHIT-CRI 70W	4.9 kg
5 NX 722 E-1MS0*	1xHIT-CRI 70W	4.9 kg
5 NX 722 E-1PB0*	1xHIT-CRI 150W	5.6 kg
5 NX 722 E-1PS0*	1xHIT-CRI 150W	5.6 kg

2. Installation

Montage

2.1 Required tools

Benötigtes Werkzeug

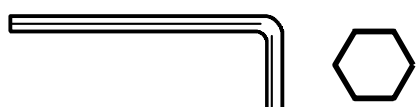
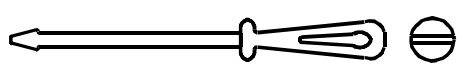
	Allen key 3mm Innensechskantschlüssel SW3 (provided / im Lieferumfang)
	Allen key 5mm Innensechskantschlüssel SW5 (provided / im Lieferumfang)
	Slotted screwdriver M3 Schlitzschraubendreher Sz3

2.2 Installation preparation Vorbereitung der Montage

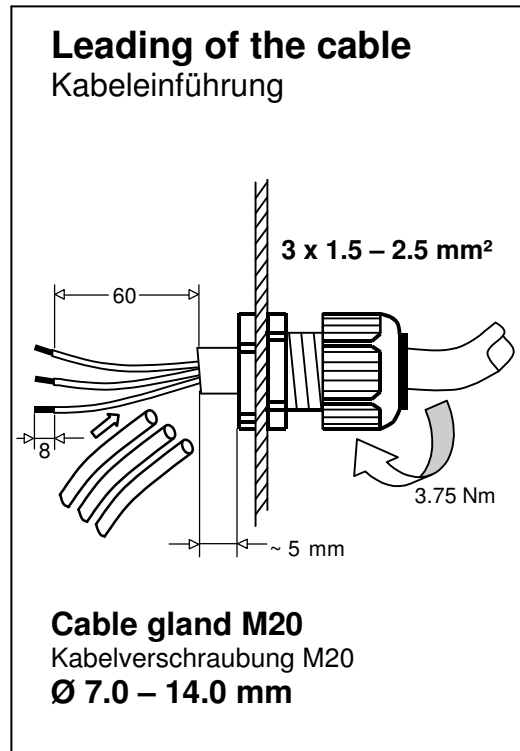
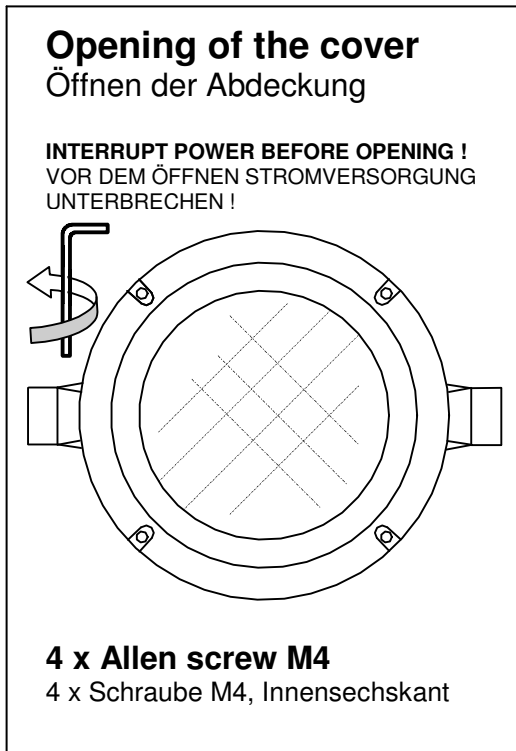

2.3 Electrical connection / Wiring diagram Elektrischer Anschluss / Schaltplan

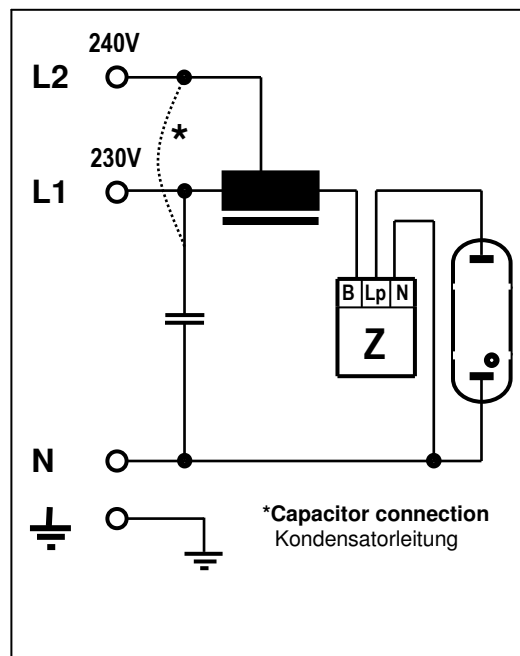
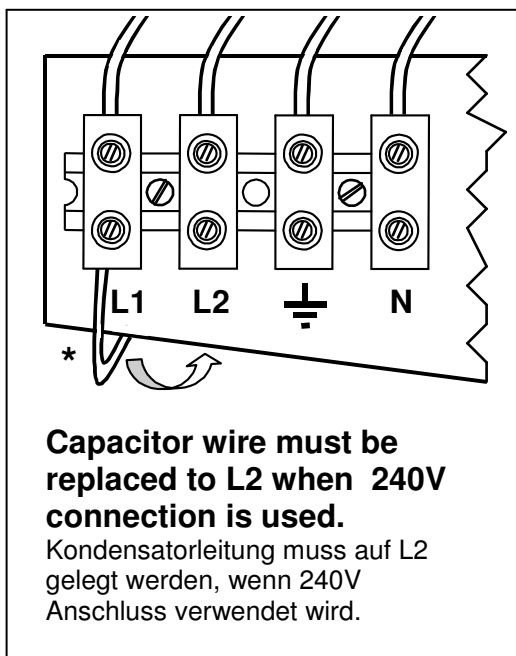

2.4 Insert of the lamp / Fixing of the cover

Einsetzen der Lampe / Schließen der Abdeckung

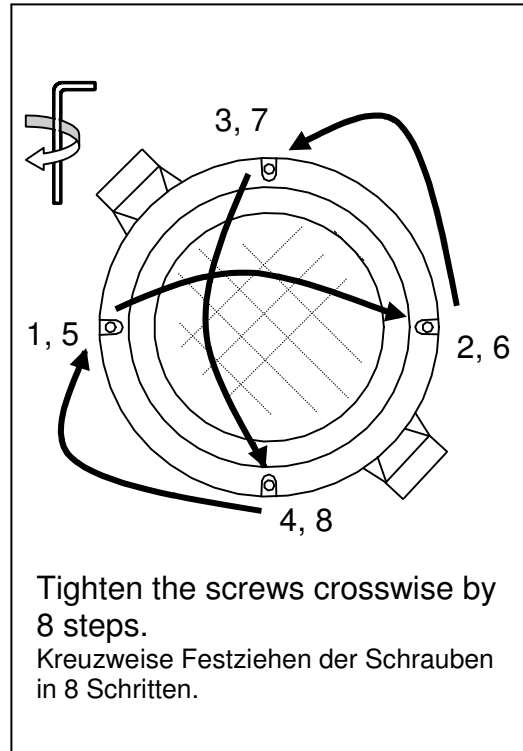
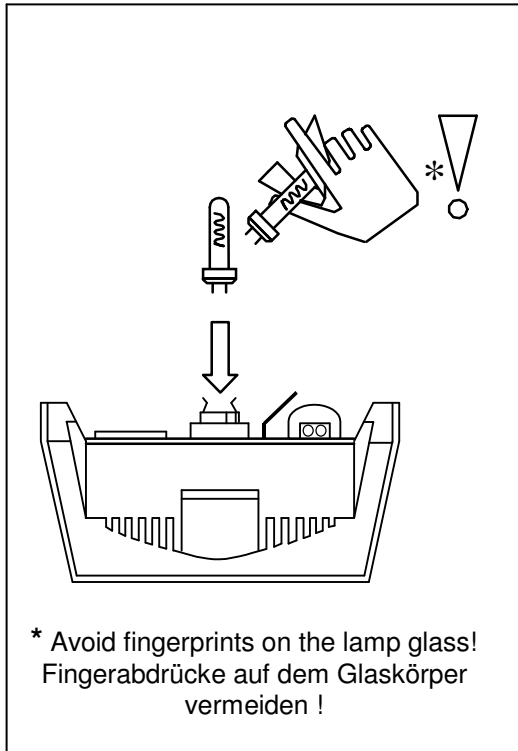

2.5 Adjustment / Operating range

Einstellung / Einstellbereich

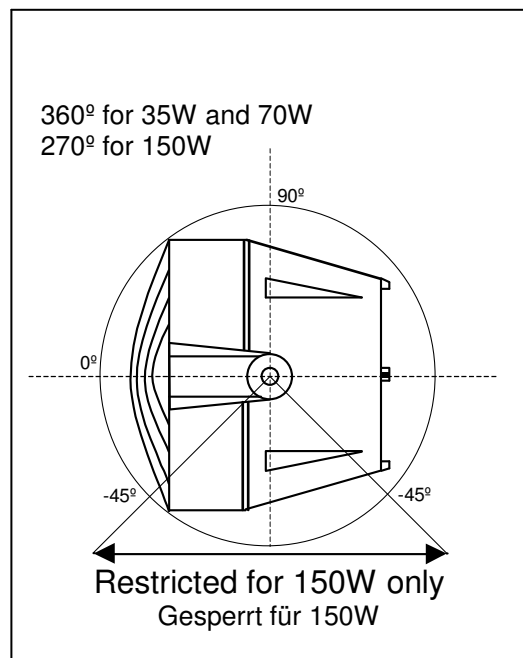
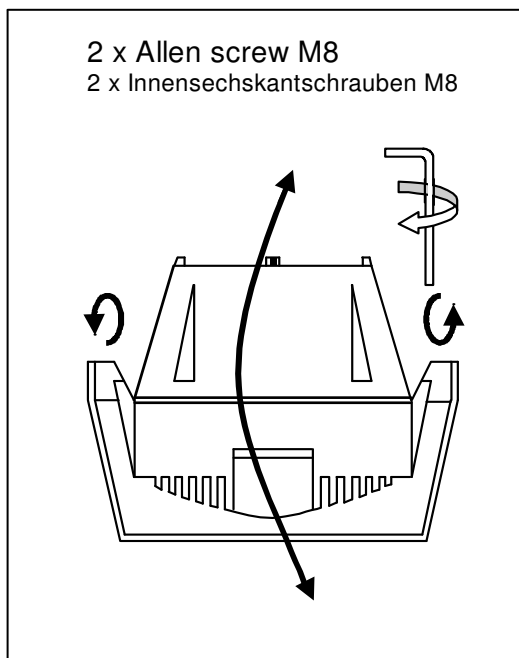

3. Accessories

Zubehör

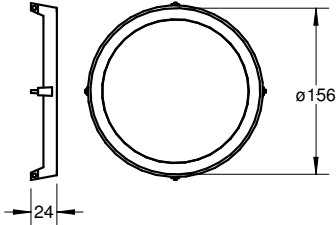
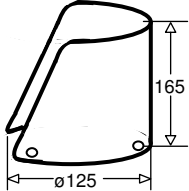
	<p>Colour filter / Farbfilter</p> <p>5 NX 724 0-0XG020* green / grün 5 NX 724 0-0XG030* red / rot 5 NX 724 0-0XG040* blue / blau 5 NX 724 0-0XG050* yellow / gelb</p> <p>*) colour identification (frame) Farbkennung (Rahmen)</p>
	<p>Anti-dazzle shield, black, 270° Aufsatzblende, schwarz, 270°</p> <p>5 NZ 724 0-0XB01</p>

For other accessories refer to the product catalogue.
 Sonstiges Zubehör siehe Katalog.

5. Safety instruction

Sicherheitshinweis

Safety distance
Sicherheitsabstand

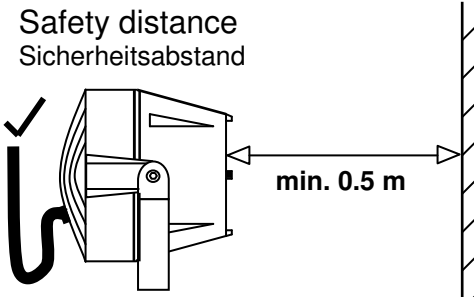

min. 0.5 m

Looping of the cable
Kabel schleifen !



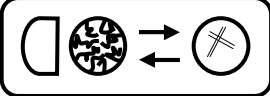

Do not operate with broken glass cover !
 Nicht mit gebrochener Scheibe betreiben !

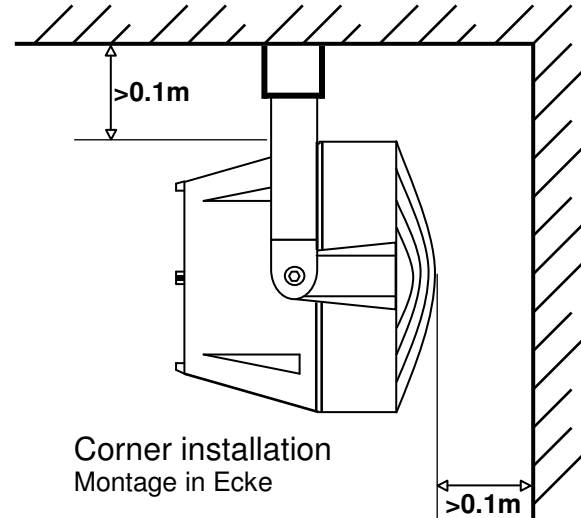

Corner installation
Montage in Ecke



Minimum distance between luminaire and lit surface.
 Minimum Abstand zur Anstrahlfläche = 0.5 Meter

Siteco Beleuchtungstechnik GmbH

Ohmstraße 50, 83301 Traunreut

Anrufen: 08669 / 33 822

Faxen: 08669 / 33 540

E-Mail: info@siteco.de

Internet: www.siteco.de

Wenn Sie technische Fragen haben:

Hotline: 08669 / 33 844

Siteco Lighting (M) Sdn Bhd

No. 18&20, Jalan Utama 2/20 Seksyen

2, Jalan Puchong

47100 Puchong, Selangor, Malaysia

Phone: 00603 8062 2466

Fax: 00603 8062 2439

E-Mail: info@siteco.com.my

Internet: www.siteco.de

Please keep for future references !

Bitte aufbewahren!

Order No. / Bestellnummer: MAL 5300.0515 a8

Copyright Siteco, 02.2004

Subject to change without notice.

Änderungen vorbehalten.