

Downlights for Compact Fluorescent Lamps



features: Lunis® recessed downlights for compact fluorescent lamps | high quality and efficiency for using different lamp types and lighting characteristics | modular system for high degree of variability | reflector system separate from control gear unit for minimum ceiling load | extensive lighting technology and decorative accessories | for operation by conventional control gear (LLCG) or high frequency gear (ECG)

application: for offices, meeting rooms, circulation zones, corridors, retail and sales zones | due to the invisible mounting ring attractive for restaurants and representative zones

design: modular design for reflector, mounting ring and remote control gear | the control gear unit can be placed on the ceiling panels or be hung within the ceiling | black powder coated mounting ring made of sheet steel | tool-free three-point reflector mounting by spring clips | reflector capsule and cover of the control gear unit are made of blue plastic | replaceable, specular reflector made of purest aluminium AL 99.98%



Order No.	Description	Lamps	Weight
5LR 112 1-1FA51	recessed downlight for compact fluorescent lamp, highly specular reflector D=180mm, H=130mm, low-loss control gear, IP 23	1 x TC-D 13W G 24d-1	1.3 kg
5LR 112 1-1GA51	recessed downlight for compact fluorescent lamp, highly specular reflector D=180mm, H=130mm, low-loss control gear, IP 23	1 x TC-D 18W G 24d-2	1.3 kg
5LR 112 1-1LA51	recessed downlight for compact fluorescent lamp, highly specular reflector D=180mm, H=130mm, low-loss control gear, IP 23	1 x TC-D 26W G 24d-3	1.3 kg
5LR 112 1-2FA51	recessed downlight for compact fluorescent lamps, highly specular reflector D=180mm, H=130mm, low-loss control gear, IP 23	2 x TC-D 13W G 24d-1	1.7 kg
5LR 112 1-2GA51	recessed downlight for compact fluorescent lamps, highly specular reflector D=180mm, H=130mm, low-loss control gear, IP 23	2 x TC-D 18W G 24d-2	1.7 kg
5LR 112 1-2LA51	recessed downlight for compact fluorescent lamps, highly specular reflector D=180mm, H=130mm, low-loss control gear, IP 23	2 x TC-D 26W G 24d-3	1.7 kg
5LR 112 7-1FA51	recessed downlight for compact fluorescent lamp, highly specular reflector D=180mm, H=130mm, electronic control gear, IP 23	1 x TC-DEL 13W G 24q-1	0.9 kg
5LR 112 7-1GA51	recessed downlight for compact fluorescent lamp, highly specular reflector D=180mm, H=130mm, electronic control gear, IP 23	1 x TC-DEL 18W G 24q-2	0.9 kg
5LR 112 7-1LA51	recessed downlight for compact fluorescent lamp, highly specular reflector D=180mm, H=130mm, electronic control gear, IP 23	1 x TC-TEL 26W Gx 24q-3	0.9 kg
5LR 112 7-2FA51	recessed downlight for compact fluorescent lamps, highly specular reflector D=180mm, H=130mm, electronic control gear, IP 23	2 x TC-DEL 13W G 24q-1	1.3 kg
5LR 112 7-2GA51	recessed downlight for compact fluorescent lamps, highly specular reflector D=180mm, H=130mm, electronic control gear, IP 23	2 x TC-DEL 18W G 24q-2	1.3 kg
5LR 112 7-2LA51	recessed downlight for compact fluorescent lamps, highly specular reflector D=180mm, H=130mm, electronic control gear, IP 23	2 x TC-TEL 26W Gx 24q-3	1.3 kg

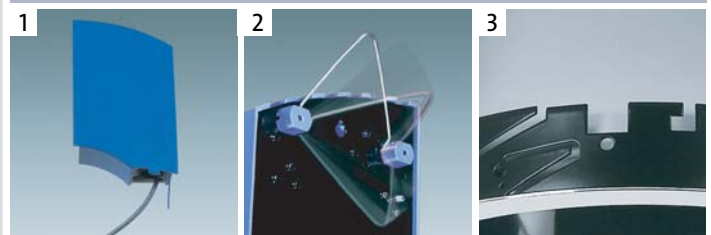

1. remote control gear unit
2. gear box hanger
3. mounting ring, black powder coated

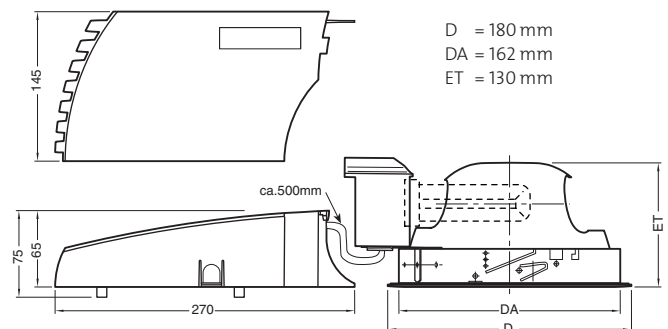

all downlights optional available with dimmable ECG

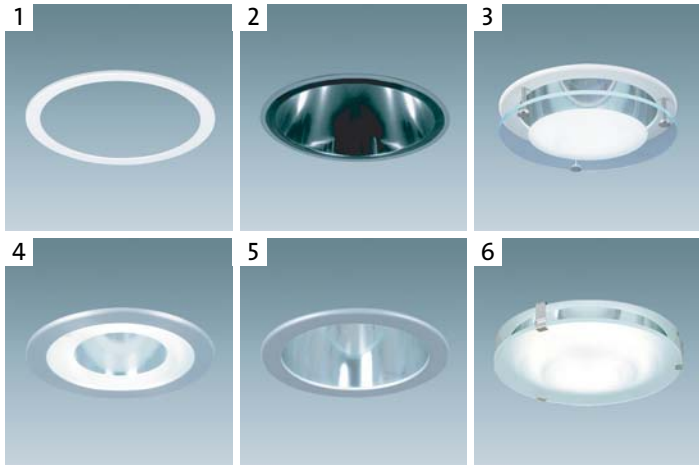

1. decorative cover ring
2. decorative ring, silicon rubber
3. float glass EXCLUSIVE, inner ring frosted
4. glass cover IP 44, outer ring frosted
5. glass cover IP 44, clear
6. float glass STANDARD, fully frosted

accessories:

Order No.	Description	Size	Weight
5LR 951 5-4GP	decorative ring made of coloured silicon rubber, white	D 180 mm	0.1 kg
5LR 951 5-6GP	decorative ring made of coloured silicon rubber, blue	D 180 mm	0.1 kg
5LR 954 5-AHP	decorative cover ring, die-cast aluminium, white, RAL 9010	D 190 mm	0.1 kg
5LR 954 5-BHP	decorative cover ring, die-cast aluminium, metallic grey, RAL 9006	D 190 mm	0.1 kg
5LR 954 5-CHP	decorative cover ring, die-cast aluminium, brushed & anodised	D 190 mm	0.1 kg
5LR 954 5-AEJ	float glass EXCLUSIVE, fixed on white* RAL 9010 mounting ring, frosted inner ring	D 190 mm	0.2 kg
5LR 954 5-AEK	float glass EXCLUSIVE, fixed on white* RAL 9010 mounting ring, frosted outer ring	D 190 mm	0.2 kg
5LR 954 5-AEL	float glass EXCLUSIVE, fixed on white* RAL 9010 mounting ring, fully frosted	D 190 mm	0.2 kg
5LR 954 5-AEA	glass cover, IP44, fixed by white* RAL 9010 mounting ring, clear	D 190 mm	0.3 kg
5LR 954 5-AEB	glass cover, IP44, fixed by white* RAL 9010 mounting ring, frosted inner ring	D 190 mm	0.3 kg
5LR 954 5-AEF	glass cover, IP44, fixed by white* RAL 9010 mounting ring, frosted outer ring	D 190 mm	0.3 kg
5LR 954 5-AEE	glass cover, IP44, fixed by white* RAL 9010 mounting ring, fully frosted	D 190 mm	0.3 kg
5LR 951 5-3EJ	float glass STANDARD, fixed on the reflector, frosted inner ring	D 180 mm	0.2 kg
5LR 951 5-3EK	float glass STANDARD, fixed on the reflector, frosted outer ring	D 180 mm	0.2 kg
5LR 951 5-3EL	float glass STANDARD, fixed on the reflector, fully frosted	D 180 mm	0.2 kg

* accessories available with rings in metallic grey RAL 9006 and rings in brushed aluminium

technical data:

rated voltage: LLCG: 220/230/240V, 50 or 60Hz
optional p.f. corrected
ECG: DC198...254V, 50...60Hz
AC 176...254V

ambient temperature: -20°C...+35°C

protection class: IP 23 (IP 44 with glass cover only)

installation:

luminaire ready wired for installation | required ceiling cut-out DA=162mm, jig provided | all components can be installed without any tools | separate control gear unit with 3-pole terminal can be pushed through the ceiling cut-out | cable length between control gear and lamp holder L=500mm | push-in mounting ring with three clips for the reflector | downlight can be operated without the reflector before the final cleaning of the construction site | push-in reflector covers the mounting ring

service and maintenance:

easy access for lamp replacement | for access to the control gear the reflector can be removed without any tooling

light distribution curve:

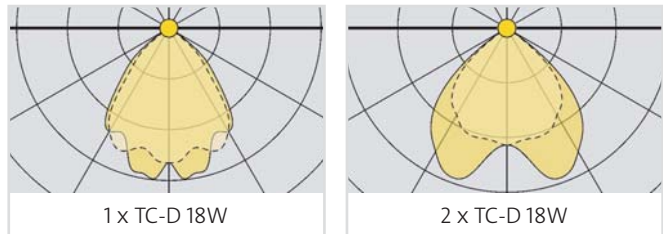

logistic:

the luminaires are individually packed in carton boxes | the cartons may be loaded individually or stacked on pallets | the capacity of the containers is based on pallet loading

	carton
335 x 220 x 245 mm (l x w x h)	

	weight
1.2 - 2.0 kg	

	pallet
50 units, 1200 x 800 x 1500 mm (l x w x h)	

	container
20' : 550 units 40' : 1100 units	